

WCM-041 Instruction Manual

For programming information: [Wired system Programming Guide](#)



For general overview: [Wired RAK Application Sheet](#)

What is the WCM-041?

The WCM-041 wired keypad is a four button keypad for use with the wired system. It will transmit Scene 1 and Off in two rooms before any custom programming is added.

WCMs require a RAK-LINK to operate as part of the system. WCMs (as part of the wired network generally) can be wired in two ways:

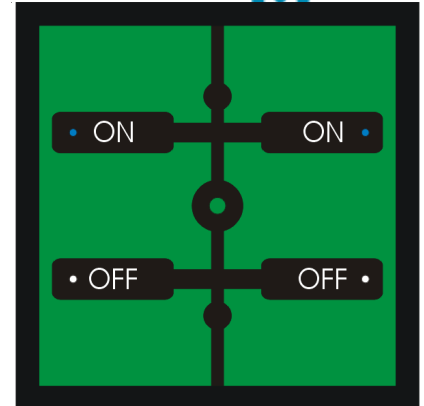

“Daisy Chain” configuration - A single run of keypads runs from the RAK-LINK and to an end point. It is still usually advisable to run a return leg back to the RAK-LINK as a spare.

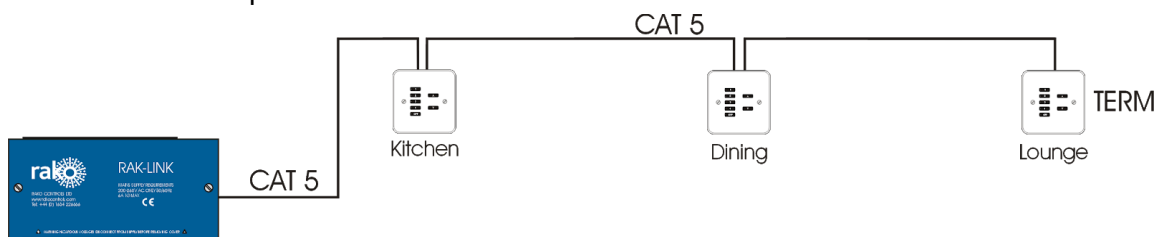

“STAR” configuration - Cables are all run back to a central point: a RAK-STAR usually located with the RAK-LINK. Each cable can be from a single keypad or a leg of keypads.

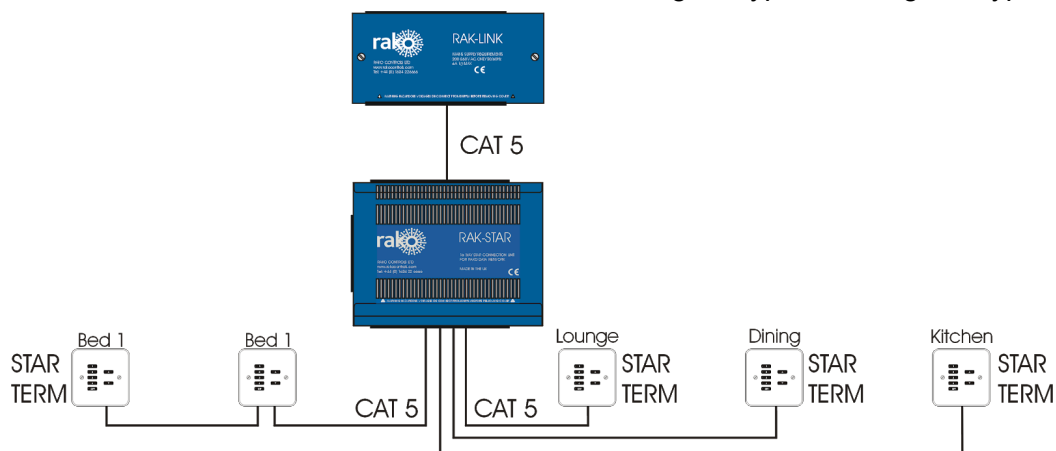

Installation Note:

The WCM comes in two sections “Front” and “Back” they are referred to as such in the following installation guide. The “Back” section is just a connection board for the CAT5/6 cable. The “Front” section contains all memory and programming.

Installation of the WCM with screwless finish plates (WLF/WLM):

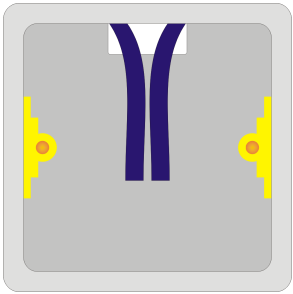
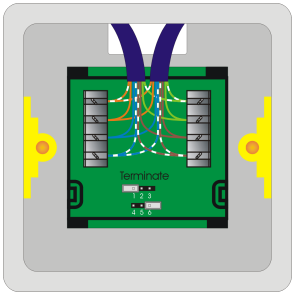
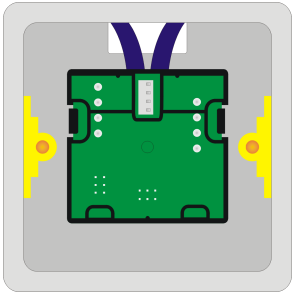
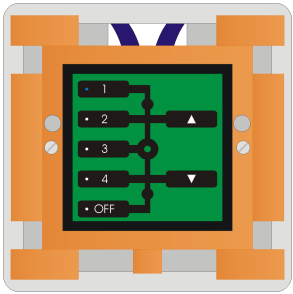
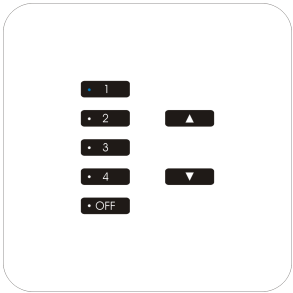
<p>Step 1</p>		<p>Prepare cable(s) in backbox ready for connection.</p> <p>Separate the two halves of the WCM ready for installation. The “back” section (with the punchdown connections) will be installed first.</p> <p>TIP: <i>Leave plenty of slack if possible to allow for re-punching down at a later date if required.</i></p>
<p>Step 2</p>		<p>Punch down cable(s) matching cable colours to colours written on the circuit board. There may be either one or two sets of cables to punch down.</p>
<p>Step 3</p>		<p>Terminate the WCM as required. See “Terminating the WCM” on page 4 of this manual.</p> <p>The back section of the WCM is now installed and is ready for the front section and cover plate.</p> <p>TIP: <i>Take care when preparing and installing not to disturb the punchdown connections. Loops are provided on the back section to cable tie the cable(s) if desired.</i></p>
<p>Step 4</p>		<p>Clip the front section of the WCM into the grid and connect the front section of the WCM to the back section of the WCM.</p> <p>Screw the grid for the screwless cover plate into the backbox.</p> <p>TIP: <i>If the wired network is powered then the backlit LEDs on the keypad will illuminate.</i></p>
<p>Step 5</p>		<p>Clip the cover plate into the grid to complete installation.</p>

Installation of the WCM with screwed finish plates (WVF):

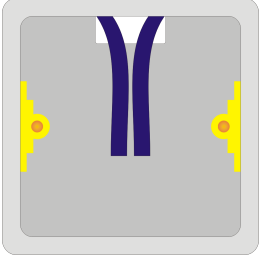
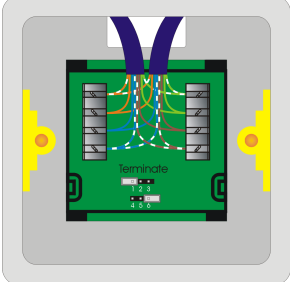
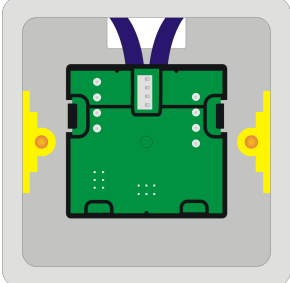
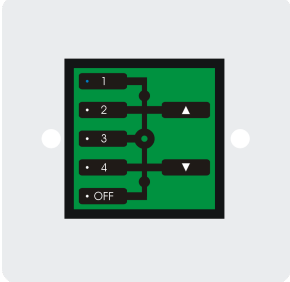
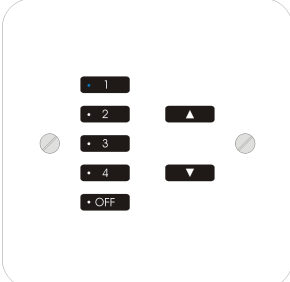
<p>Step 1</p>		<p>Prepare cable(s) in backbox ready for connection.</p> <p>Separate the two halves of the WCM ready for installation. The “back” section (with the punchdown connections) will be installed first.</p> <p>TIP: <i>Leave plenty of slack if possible to allow for re-punching down at a later date if required.</i></p>
<p>Step 2</p>		<p>Punch down cable(s) matching cable colours to colours written on the circuit board. There may be either one or two sets of cables to punch down.</p> <p>Terminate the WCM as required. See “Terminating the WCM” on page 4 of this manual.</p>
<p>Step 3</p>		<p>The back section of the WCM is now installed and is ready for the front section and cover plate.</p> <p>TIP: <i>Take care when preparing and installing not to disturb the punch down connections. Loops are provided on the back section to cable tie the cable(s) if desired.</i></p>
<p>Step 4</p>		<p>Clip the transparent surrounding mounting plate and the WCM front board together.</p> <p>Fit the WCM front board and attached surround to the WCM back board.</p> <p>TIP: <i>If the wired network is powered then the backlit LEDs on the keypad should illuminate once the two halves are connected together.</i></p>
<p>Step 5</p>		<p>Finally screw the cover plate into the back box through the screw holes in the transparent surround.</p> <p>Installation of the WCM is now complete.</p>

Terminating the WCM

It is important to terminate WCMs correctly otherwise the wired system will not function. The termination that is required depends on the nature of the installation and the position of the RAK-LINK within the system.

No Term - Both Jumpers removed

Used when the WCM is not at the end of line. This is usually identifiable by two cables being punched down to the WCM.

Term - Jumper fitted across 1+2 & 4+5

Used when the WCM is end of line in a daisy chain configuration. For example the WCM marked "TERM" shown in "Typical Wired Installation layout" on page one.

Star Term - Jumper fitted across 2+3 & 5+6

Used when the WCM is end of line in a STAR wire configuration. For the example the WCMs marked "STAR TERM" on page one.

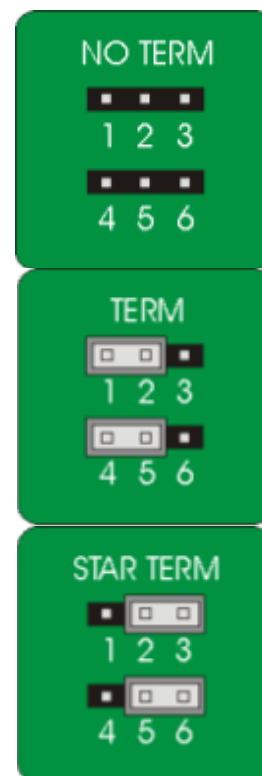

Programming the WCM

The WCM is programmed using the Rasoft Pro programming software. A WAWTC-Bridge is required for any programming of a wired system.

[Wired system Programming Guide](#) - For information on how to programme the wired system using Rasoft Pro.

Troubleshooting the Wired Network

Sometimes cabling problems or incorrectly punched down cables means a degree of fault finding needs to be done on the wired network. The WCMs use backlit LEDs to provide fault codes and this can be used in combination with the guides below to resolve problems.

[WCM Diagnostic Feedback](#) - For fault finding "Daisy Chain" and "Star" configuration.

[RAK-LINK diagnostics](#) - For fault finding "Daisy Chain" and "Star" configuration.

[RAK-STAR diagnostics](#) - For fault finding "Star" configuration.

Rako thanks you for having purchased a Rako product and hopes that you are pleased with your system. Should for any reason you need to contact us please contact us via our website www.rakocontrols.com or by phoning our customer help line on 01634 226666.

