



# Instruction Manual

# WCM

Wired push button control module



2024  
Version 2.1.0



For programming system programming information: [Wired system setup guide](#).

For a general overview: [Wired RAK application sheet](#).

## Contents

1. [What is the WCM?](#)
2. [Installation](#)
  - 2.1. [Screwless plates](#)
  - 2.2. [Screwed plates](#)
3. [Terminating the WCM](#)
4. [Button configurations](#)
5. [Programming the WCM](#)
6. [Appendix 1: Troubleshooting the Wired Network](#)
7. [Appendix 2: System wiring examples](#)



## 1 What is the WCM?

The WCM is a wall controller for use within a Rako Wired system, it is designed to fit in a standard UK back box for wall mounting.

Depending on the WCM requirement, many button configurations are possible, ranging from Lighting, Blind and Audio control.

Through Rasoft Pro, commands can be assigned to the buttons to perform actions, such as switching a Scene for a Room or closing Blinds.

Commands include:

- Scenes 1 to 16
- Toggles for individual Channels or Rooms.
- Fade Up/Fade Down for individual Channels or Rooms
- Levels (0-100%)
- Multiple commands on a single input
- Press and hold
- Press and release
- Whole House commands



## 2 Installation

### NB

The WCM comes in two parts, the installation guide refers to the 'Back' as the part which has the cable connections, and the 'Front' which has a four-pin connector which contains all of the programming.

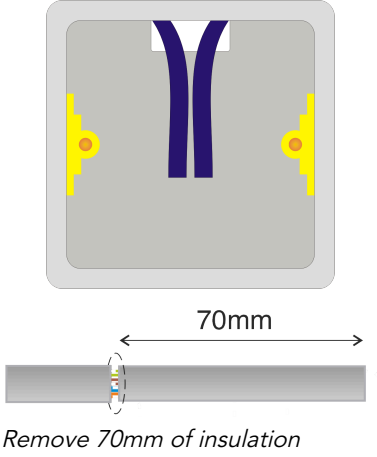
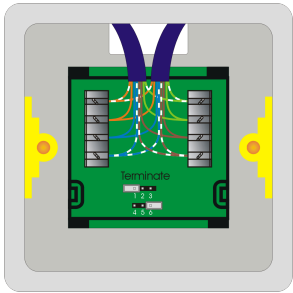
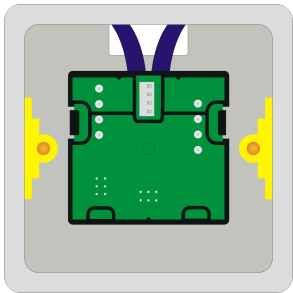

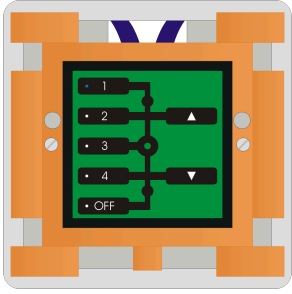
### 2.1 Installation of the WCM (Screwless plates)

|               |   |   |
|---------------|---|---|
| <b>Step 1</b> |  <p>Remove 70mm of insulation</p> | <p>Bring the cable(s) into the backbox, and strip 70mm of the outer insulation, exposing the data cable.</p> <p><u>NB</u></p> <p><i>Leave plenty of slack if possible to allow for re-punching down later if required.</i></p>  |
| <b>Step 2</b> |                                  | <p>Using a Punch Down tool, connect the cable cores to the labelled inputs on the WCM 'Back' section.</p> <p>Ensure that the cable cores are not loose in the connector, as this will result in intermittent faults.</p>  |
| <b>Step 3</b> |                                  | <p>Set the appropriate jumper termination on the 'back' section of the WCM, the termination arrangement will depend on the WCM's position in the Wired network, see section 4 for more information.</p> <p><u>NB</u></p> <p><i>Take care when preparing and installing to avoid disturbing the punch-down connections. Loops are provided on the back section to tie the cable(s) if desired.</i></p> |

|               |   |  |
|---------------|---|--|
| <p>Step 4</p> |  | <p>Clip the front section of the WCM into the grid and connect the front section of the WCM to the back section of the WCM.</p> <p>Screw the grid for the screwless cover plate into the backbox.</p> <p><b>NB</b><br/><i>If the Wired network is powered then the backlit LEDs on the keypad will illuminate.</i></p> |
| <p>Step 5</p> |  | <p>Clip the cover plate into the grid to complete the installation.</p>  |

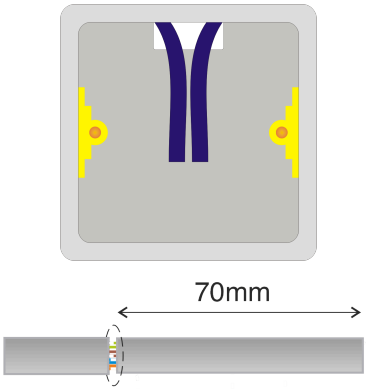
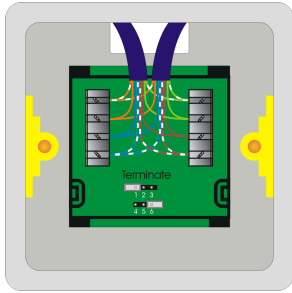
## 2.2 Installation of the WCM (Screwed plates)

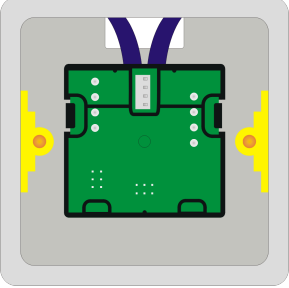
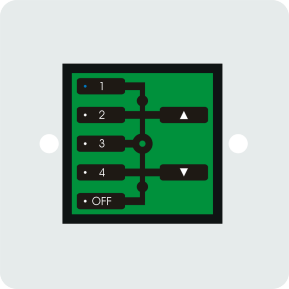
|               |   |  |
|---------------|---|--|
| <p>Step 1</p> |  | <p>Bring the cable(s) into the backbox, and strip 70mm of the outer insulation, exposing the data cable.</p> <p><b>NB</b><br/><i>Leave plenty of slack if possible to allow for re-punching down later if required.</i></p>                          |
| <p>Step 2</p> |  | <p>Punch down cable(s) matching cable colours to colours printed on the circuit board. There may be either one or two sets of cables to punch down.</p> <p>Terminate the WCM as required. See "Terminating the WCM" in section 4 of this manual.</p> |

|                      |  |   |
|----------------------|--|---|
| <p><b>Step 3</b></p> |   | <p>The back section of the WCM is now installed and is ready for the front section and cover plate.</p> <p><b>NB</b><br/> <i>Take care when preparing and installing to avoid disturbing the punch-down connections. Loops are provided on the back section to tie the cable(s) if desired.</i></p>                           |
| <p><b>Step 4</b></p> |   | <p>Clip the transparent surrounding mounting plate and the WCM front board together.</p> <p>Fit the WCM front board and attach the surround to the WCM backboard.</p> <p><b>TIP:</b><br/> <i>If the Wired network is powered then the backlit LEDs on the keypad should illuminate once the two halves are connected.</i></p> |
| <p><b>Step 5</b></p> |  | <p>Screw the cover plate into the back box through the screw holes in the transparent surround.</p> <p>Installation of the WCM is now complete.</p>   |

### 3 Terminating the WCM

It is important to terminate WCMs correctly otherwise the Wired system will not function. The termination that is required depends on the nature of the installation and the position of the RAK-LINK within the system.

#### No Term - Both Jumpers removed

Used when the WCM is not at the end of line. This is usually identifiable by two cables being punched down to the WCM.

#### Term - Jumper fitted across 1+2 & 4+5

Used when the WCM is end of line in a daisy chain configuration.

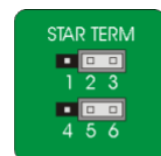
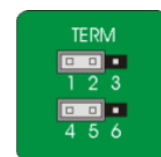
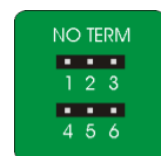

#### Star Term - Jumper fitted across 2+3 & 5+6

Used when the WCM is the end of line in a STAR wire configuration.

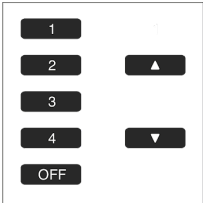
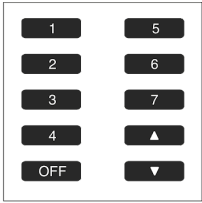

## 4 Button configurations

The WCM is capable of having up to ten buttons to control Lighting and Blinds. Custom button layouts can be created on the [Plate Designer](#); the standard button layouts are below:

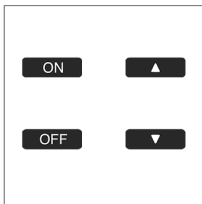
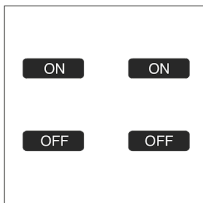
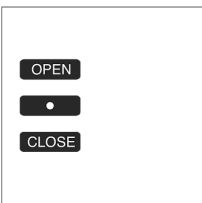
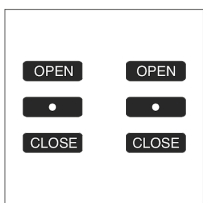
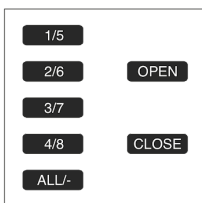
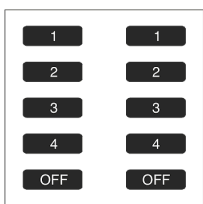
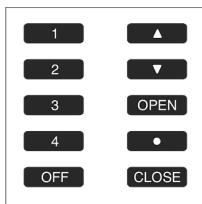
| Layout   | Description                               | Layout  | Description  |
|--|---|---|--|
|  <p>WCM-070</p>   | Scenes 1-4, Off and Raise/Lower           |  <p>WCM-100</p>   | Scenes 1-7 and Off.  |
|  <p>WCM-020</p>  | Scene 1 and Off                           |  <p>WCM-040</p>  | Scene 1, Off and Raise/Lower   |
|  <p>WCM-041</p> | Dual Room Control, Scene 1 and Off.       |  <p>WCM-030</p> | Open, Stop and Close.  |
|  <p>WCM-060</p> | Dual Blind control, Open, Stop and Close. |  <p>WCM-071</p> | Multi-Blind selector.<br>Controls up to 8 individual Blinds or as a group.               |
|  <p>WCM-103</p> | Dual Room Control, Scenes 1-4 and Off.    |  <p>WCM-101</p> | Scenes 1-4, Off and Raise/Lower for lighting.<br>Open, Stop and Close for Blind control. |

## 5 Programming the WCM

Before the WCM can operate Lighting or Blinds, it needs to be programmed into a Wired system using Rasoft Pro and a Wired programming Device, such as the WK-HUB or a WA/WTC-Bridge.

For instructions on how to do this, please refer to the Wired programming guide:

[Wired system setup guide.](#)

Thank you for choosing Rako Controls; we hope that you are pleased with your system. Should you require further assistance, please contact us via our website, [www.rakocontrols.com](http://www.rakocontrols.com), or by calling our customer support helpline on 01634 226666.



## 6 Appendix 1: Troubleshooting the Wired Network

Sometimes cabling problems or incorrectly punched down cables mean a degree of fault finding needs to be done on the Wired network. The WCMs use backlit LEDs to provide fault codes, which can be combined with the guides below to resolve problems.

[Wired LED Diagnostics](#) - Diagnostics for specific LED patterns on the WCM

[RAK-LINK diagnostics](#) - For fault finding, "Daisy Chain" and "Star" configuration.

[RAK-STAR diagnostics](#) - For fault finding, "STAR" configuration.

## 7 Appendix 2: System Wiring Examples

### Radial Wiring

A Radial system consists of one or more Wired Devices connected in a loop-in/loop-out arrangement. The end of line points should be terminated in the 'Term' configuration.

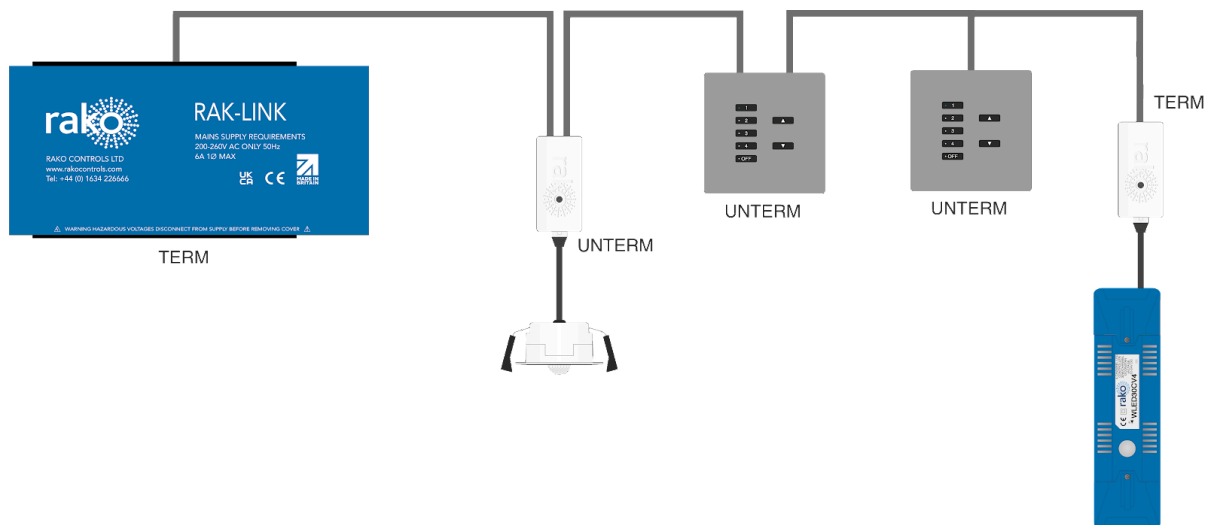



## STAR Wiring

A STAR Wired system has individual runs from one or more RAK-STAR units to the Wired Devices, every end of line in a STAR system should have the STAR termination.

### NB

More than one Device can be connected to a leg on a STAR system, Devices in the middle of a loop in/loop out should be set to TERM, and the end of lines should be set to STAR.

