



Instruction Manual

RAK-STAR

16-Way Connection Unit



2025

Version 2.0.1



For programming and diagnostic information, see [Wired Programming Guide./Wired LED Diagnostics](#)

For general system information, see the [Wired Application Sheet](#).

Contents

1. [What is the RAK-STAR?](#)
2. [Leg Inputs](#)
3. [Installation Principles](#)
4. [Installation Instructions](#)
5. [Terminating devices](#)
6. [Appendix 1: Wiring examples](#)
7. [Appendix 2: Core voltage table](#)
8. [Appendix 3: Troubleshooting](#)





1. [What is the RAK-STAR?](#)

The RAK-STAR is a 16-way distribution board for centrally run CAT5 or CAT6 wiring. The RAK-STAR has no internal power supply as this is supplied by a connected RAK-LINK.

The RAK-STAR is used when there are more than two centrally run cables in a single location. There can be multiple RAK-STARs in a system.

2. [Leg Inputs](#)

Name	Image	Description
Punchdown Connector		CAT5 or CAT6 cables are terminated into the punchdown connector using a punchdown tool.

Data Switch		Controls the data on the leg of the RAK-STAR; unused legs should be set in the off position. When data is being used, set the data switch to the up position.
Power Jumper	 +15V	Enables voltage to flow through the connected leg; if there is no jumper connected, there will be no power on the leg.
RJ11 Port		A Rako wired accessory may be connected to the RAK-STAR via the RJ11 port if desired.

3. Installation Principles

- Each RAK-STAR punch-down connector can accept a single CAT5 or CAT6 cable, using more than one cable will result in intermittent operation of the wired network, if required, add an additional RAK-STAR (see wiring diagrams in Appendix 1)
- There should only be one power source per RAK-STAR; if there are multiple RAK-LINK's connected to the RAK-STAR, the power jumpers must be removed
- If multiple RAK-STAR units are required, legs 1 and 18 should be reserved for connections between each RAK-STAR unit.
- The RAK-STAR punchdown connections require eight cores. Four-core systems with more than two home-run cables require the WA-NEX module.
- Cables should be point-to-point tested and identified before being connected to the RAK-STAR
- Do not connect the RAK8-MB to the RAK-STAR; they use two separate communication protocols and may result in damage to both units

4. Installation

POWER SHOULD BE ISOLATED THROUGHOUT THE INSTALLATION PROCESS

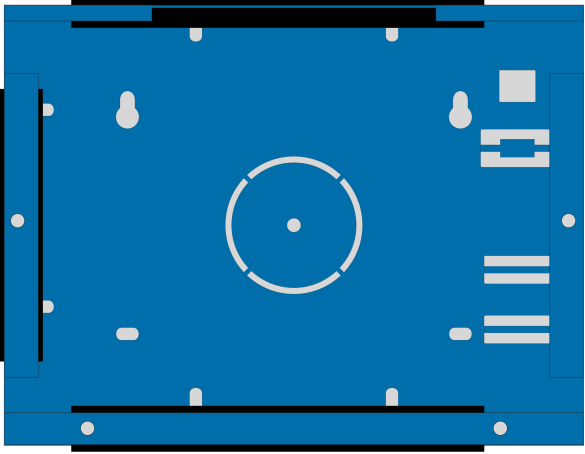
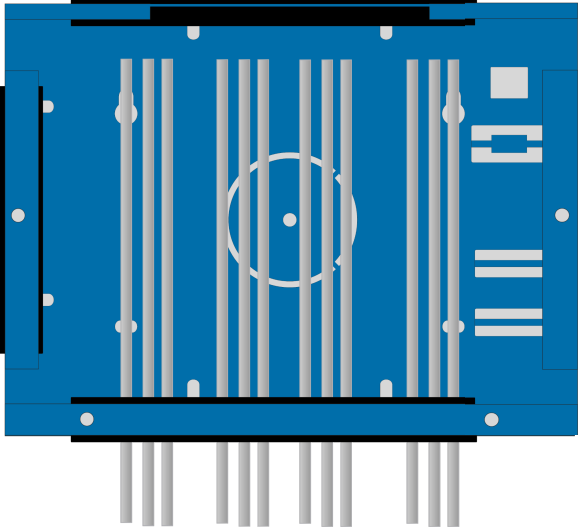
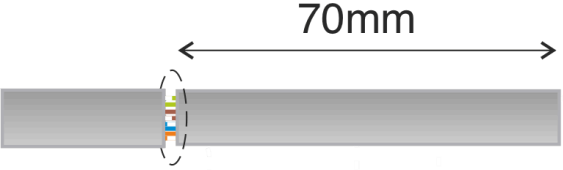
Step 1		<p>Secure the back of the metal housing to the wall or secure mounting position.</p> <p>NB The RAK system is designed to be mounted in columns for cable management.</p>
Step 2		<p>Bring in the CAT5/CAT6 cables for the Wired devices into the RAK-STAR via the knockouts on either the top, bottom, or left-hand side.</p> <p>The RAK-LINK will provide power for the devices on the RAK-STAR.</p>
Step 3		<p>Strip each of the CAT5/CAT6 cables ready for termination into the RAK-STAR</p>

Step 4

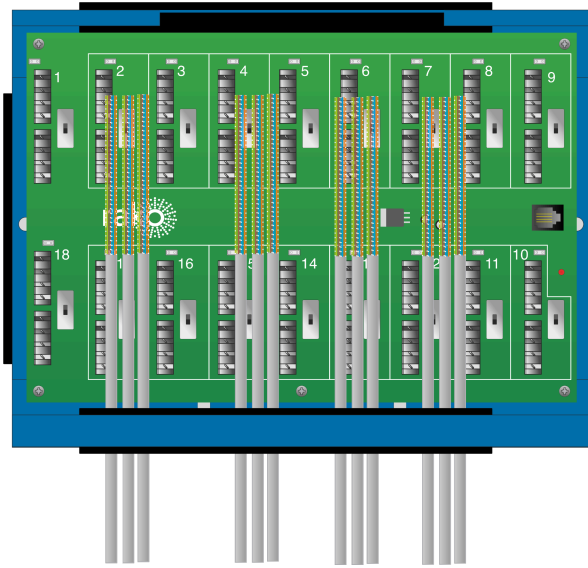

Place the RAK-STAR circuit board on the two screws on either side of the metalwork, ensuring that the stripped CAT5 or CAT6 cables are sitting on top.

Tighten the two screws to secure the circuit board.

Step 5

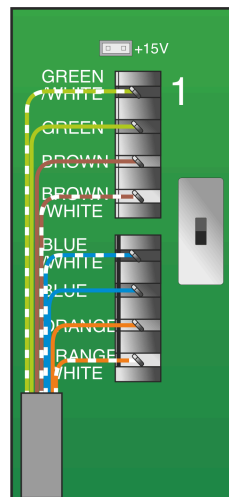

Using a punchdown tool, terminate the CAT5 or CAT6 cables in the legs of the RAK-STAR.

Once all cables have been terminated, the data switches should be switched to the on position, and the power jumpers should be set.

NB
The CAT5/CAT6 for the RAK-LINK should be the first device to connect to the RAK-STAR.

5. Terminating devices connected to the RAK-STAR

Devices connected to the RAK-STAR require a 'STAR' termination if at the end of line on a cable run, if a device is in between a run it should be set to 'NO TERM'.

No TERM: Both Jumpers are removed

When a device is not at the end of line.

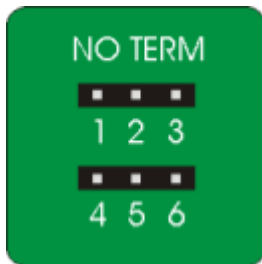

STAR TERM: Jumper fitted across 2+3 and 5+6

When a device is at the end of line, in a RAK-STAR System it must be STAR terminated.

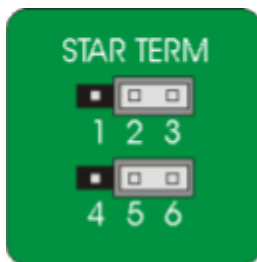

TERM: Jumper fitted across 1+2 and 4+5

This is not used on the RAK-STAR; TERM is used At each end of a Radial system.

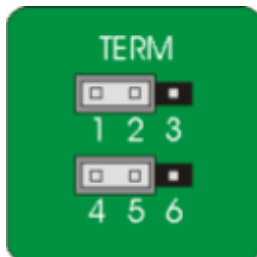

Thank you for choosing Rako Controls; we hope that you are pleased with your system. Should you require further assistance, please contact us via our website, www.rakocontrols.com, or by calling our customer support helpline on 01634 226666.



Appendix 1: Wiring examples

One RAK-STAR

The system below shows a RAK-STAR joining multiple devices together to form a Rako Wired Network. The RAK-LINK has a power supply, which supplies the devices connected to the RAK-STAR.

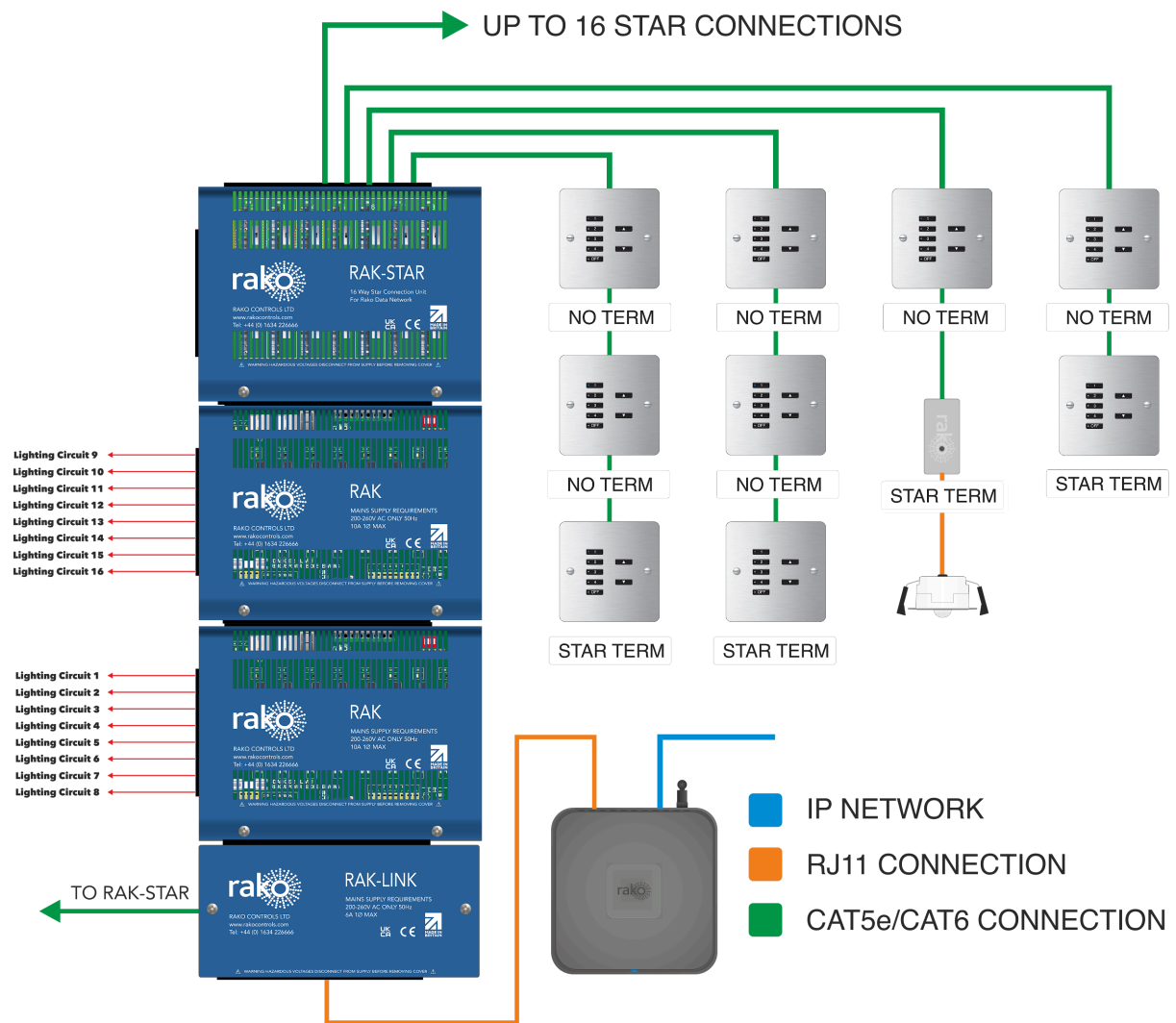

Multiple RAK-STARs

When a wired system is large and requires more than one RAK-STAR, it must be connected in a loop-in/loop-out arrangement.

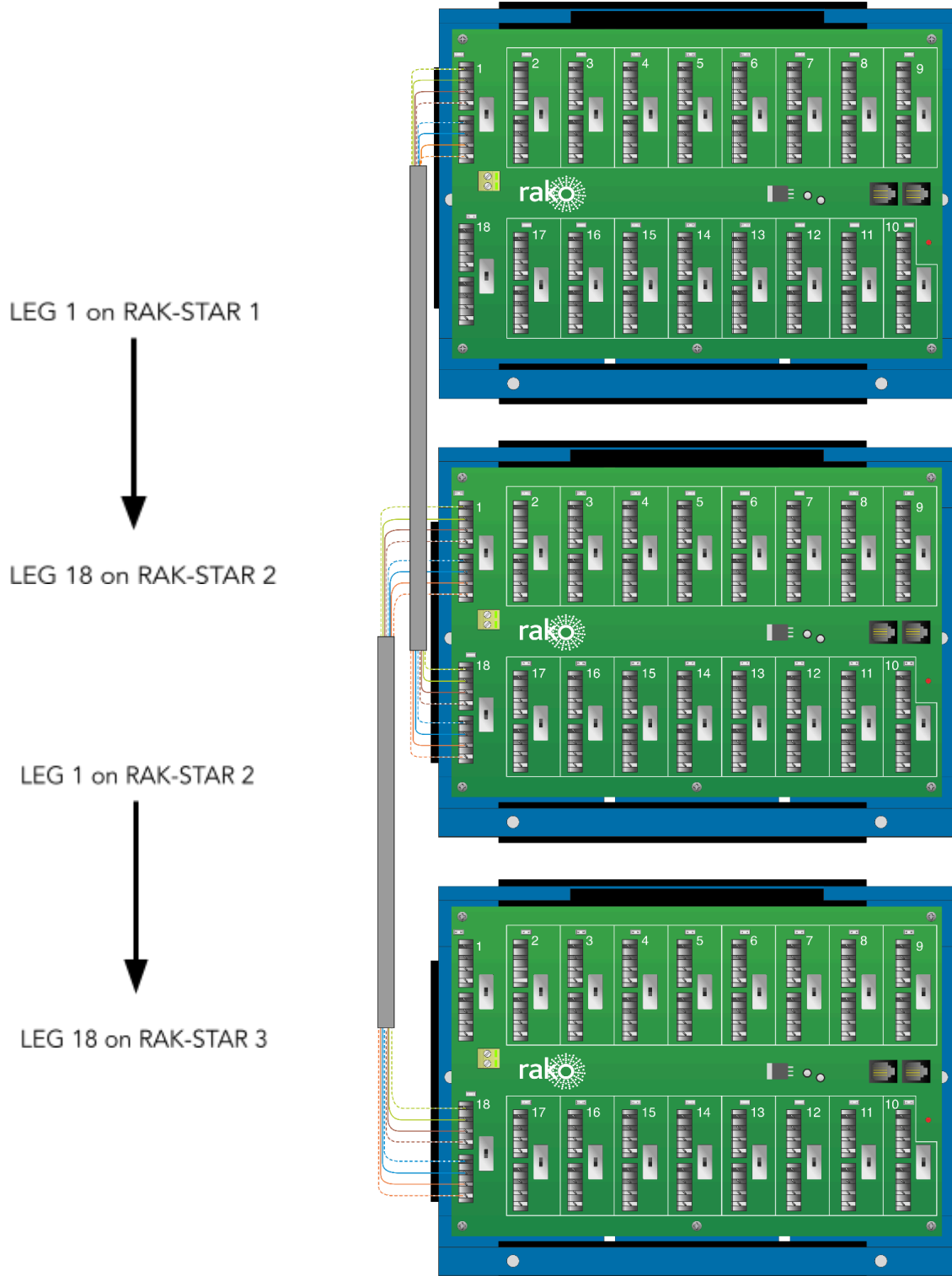

Appendix 2: Core voltage table

Core Colour	Function	Typical Value
Green/White	Data + (return)	2.5-3V
Green	Data - (return)	2.5-3V
Brown	Power -	0V
Brown/White	Power +	15V
Blue/White	Data +	2.5-3V
Blue	Data -	2.5-3V
Orange	Power -	0V
Orange/White	Power +	15V

Appendix 3: Troubleshooting

Fault description	Solution
There is no power on the RAK-STAR.	<p>Remove all power jumpers on every leg of the RAK-STAR apart from the RAK-LINK leg</p> <p>If the fault clears, introduce one power jumper at a time until the red light on the RAK-STAR goes off. Investigate the legs for short circuits.</p>
No devices are showing up online.	<p>Put all data switches in the off position, apart from the RAK-LINK, and verify the RAK-LINK is online.</p> <p>In sequence, introduce one data switch at a time while verifying the devices are coming online, and isolate and investigate the wiring on any legs that cause devices to go offline.</p>
Devices intermittently go offline and online.	<p>Check the system size, if there are more than two fully populated RAK-STAR units or the total cable length has exceeded 1.5km, the system will require partitioning with the WA-NEX.</p> <p>Check the voltage on the wired network, it should be between 13-15VDC, if the voltage is too low test the RAK-LINK power supply in isolation.</p>
Data gets to a certain point but does not go further.	<p>Check the 'STAR' terminations on the surrounding legs, for example: if the data only reaches leg 6, investigate leg 5 and leg 7.</p>