



# DIN System Overview



2026  
Version 1.0.2



# Contents

1 Introduction	3
2 DIN-LINK	3
3 DIN-CONNECT	3
4 DIN-PSU-100	4
5 DIN Control Modules	4
6 Keypads and Accessories	5
7 Example Systems	7
7.1 Radial System	7
7.2 STAR System	8
7.3 Systems with Multiple DIN-LINKs	8
8 System Configuration & Programming	9
8.1 Rasoft Pro	9
8.2 WK-HUB Network Interface	9

# 1 Introduction

DIN rail-mounted systems are a widely adopted standard in electrical and automation installations, providing a structured method for organising modules, commonly referred to as DIN cabinets or consumer units. These systems utilise a standardised metal rail to securely mount a variety of devices such as circuit breakers, power supplies and control modules.

Leveraging this industry-standard platform, the Rako DIN range offers a modular control solution dedicated to lighting control, curtain and blind control and third-party interfacing via relays.

All Rako DIN systems begin with at least one DIN-LINK module. It is the communicator between the two core protocols of the Rako DIN system, the DIN bus and the Rako Wired Network (RWN). The DIN-LINK requires a DIN-PSU-100 for input power and a DIN-CONNECT for communication with Rako products outside of the DIN system. The content to follow will provide an overview of the Rako DIN system and its core elements.

## 2 DIN-LINK

The DIN-LINK is an essential module in the Rako DIN system. Its primary functions are for power and communication for the DIN-BUS and RWN.



## 3 DIN-CONNECT

The DIN-CONNECT is a connector designed for use with the Rako DIN system and Rako Wired Network.

It provides two connection points: an RJ45 port for connecting to the DIN-LINK, and a Krone connector that accommodates up to two CAT5 or CAT6 connections to the Rako Wired Network.

The DIN-CONNECT can be used in Radial and Star wiring arrangements on the Rako Wired Network.



## 4 DIN-PSU-100



The DIN-PSU-100 is a dedicated power supply unit which provides power for the DIN-LINK modules and Rako Wired Network.



## 5 DIN Control Modules

There are four DIN rail-mounted control modules available to suit specific load types. The DIN modules communicate via the DIN Bus via the DIN-LINK.



Device	Description	Diagram
DIN-4T	Four-channel trailing edge dimmer module. Suitable for controlling mains dimmable loads such as compatible LED lamps and traditional tungsten or low-voltage halogen lighting (with appropriate transformers).	
DIN-8S	Eight-channel relay module providing on/off switching for a variety of non-dimmable loads. Each channel can be independently controlled.	



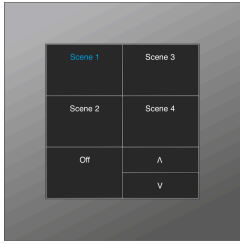
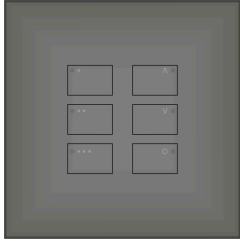

<p>DIN-4C</p>	<p>A four-channel curtain and blind controller module.</p> <p>Provides dual relay outputs per channel, suitable for controlling motorised blinds, curtains, or screens requiring separate open/close commands.</p>	 <p>The image shows the Rako DIN-4C controller module. It features a top section with a display and buttons, a middle section with the 'rako' logo and 'DIN-4C' text, and a bottom section with four channels labeled CH1, CH2, CH3, and CH4. Each channel has two relay outputs labeled A1 and B1.</p>
<p>DIN-DLI</p>	<p>The DIN-DLI is a multi-room DALI controller for up to 16 Rako Rooms and up to 64 DALI ballasts.</p> <p>The DIN-DLI supports both RGBW and colour-tunable loads when using the appropriate DT6 and DT8 ballasts.</p>	 <p>The image shows the Rako DIN-DLI controller module. It features a top section with a display and buttons, a middle section with the 'rako' logo and 'DIN-DLI' text, and a bottom section with a single output labeled DA.</p>

## 6 Keypads and Accessories

The Rako DIN system is controlled by Keypads and Accessories, which are installed and connected outside of the DIN enclosure and communicate solely via the RWN.

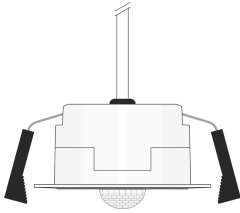
It is also possible to control Rako DIN systems using Rako wireless products via a WK-HUB or WRB100.

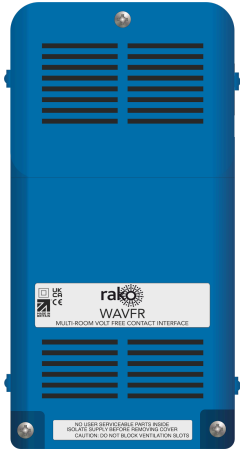
Device	Description	Diagram
WCM	The WCM has up to 10 programmable buttons which can be configured using Rasoft Pro to perform actions such as scenes, toggles, fades and levels. The commands can be programmed to control individual channels or whole rooms.	
WK-MOD	The WK-MOD has 12 programmable buttons for scenes, toggles, fades and levels. The buttons can be programmed to control individual channels or whole rooms.	
WK-EOS	The WK-EOS offers up to six customisable buttons when configured using Rasoft Pro. Actions such as scenes, toggles, fades and levels. The commands can be programmed to control individual channels or whole rooms.	
WCM-D	The WCM-D is used to interface between third-party switches and the Rako Wired Network, both units are installed locally at the switching location.  Switch inputs can be mapped to perform actions such as scenes, toggles, fades and levels using Rasoft Pro.	
WK-PIR	The WK-PIR is a presence detector that communicates via the RWN.  It allows the DIN system to be controlled based on occupancy, features three modes of	

	<p>conditional triggering as well as an extensive and highly customisable programming interface.</p>	
<p>WAVMI</p>	<p>The WAVMI is a mains switching interface used in a Rako Wired network. It has five mains switching inputs.</p> <p>The purpose of the WAVMI is to interface with 3rd party switching controllers such as a PIR, Fire Alarm or Gate Control</p>	
<p>WAVFR</p>	<p>The WAVFR is a 10-way volt free interface.</p> <p>Each input can be programmed to its own Room and Channel, and each input has two states, 'on make' and 'on break' which can be configured to trigger a command for each state that the switch is in.</p>	
<p>WK-HUB</p>	<p>The WK-HUB enables programming of the DIN system and has a built-in wireless receiver, which enables Rako wireless keypads and input devices to control the DIN system. Additional features include app control, holiday mode, macros, and mappings.</p>	

<p>WRB100</p>	<p>The WRB100 is a command repeater that can be used as a wireless receiver for the DIN system. It features a punch-down connector and an RJ11 connector for two methods of joining the Rako Wired Network.</p> <p>When connected, the WRB100 can receive commands from wireless keypads to control the DIN modules.</p>	
---------------	--	---

## 7.0 Example Systems

The RWN is typically wired using CAT5 or CAT6 in the following configurations:

### 7.1 Radial System

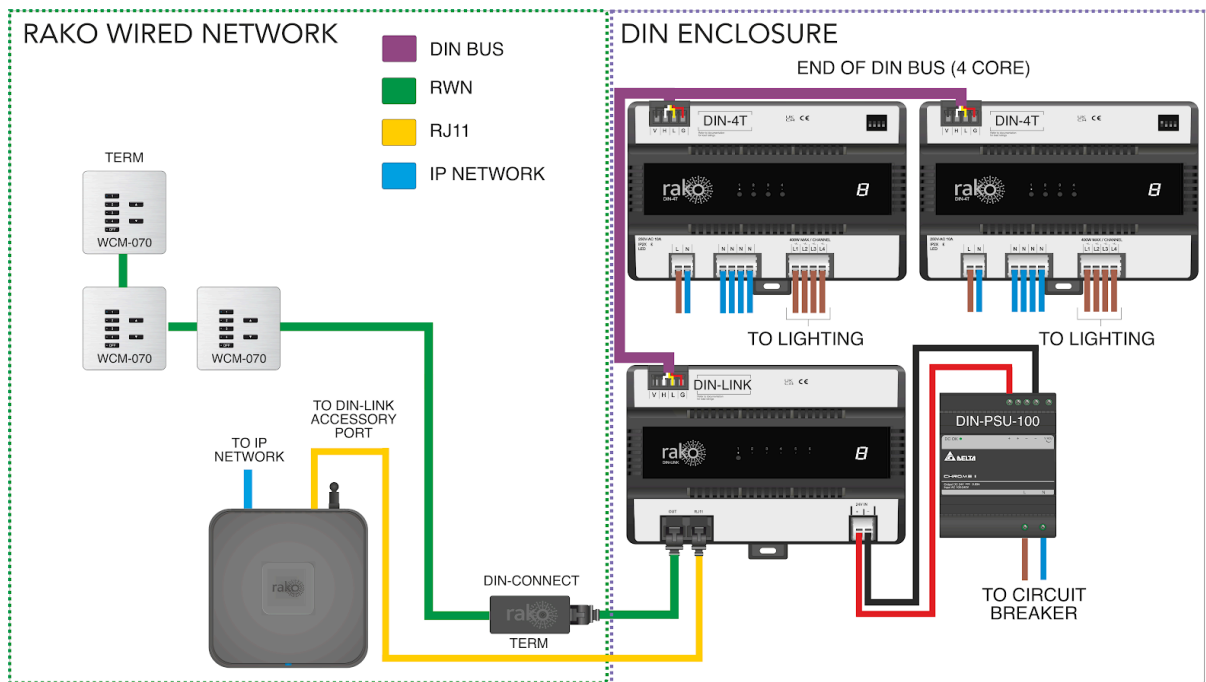

## 7.2 STAR System

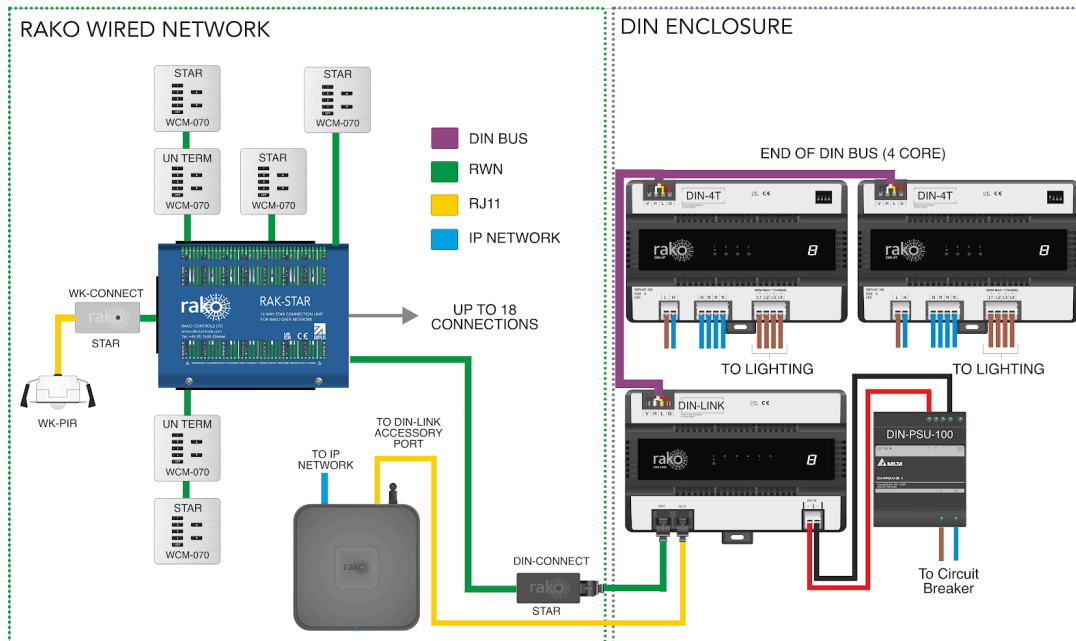

## 7.3 Systems with Multiple DIN-LINKs

If the DIN system requires more than one DIN-LINK, they must be connected via the Rako Wired Network.

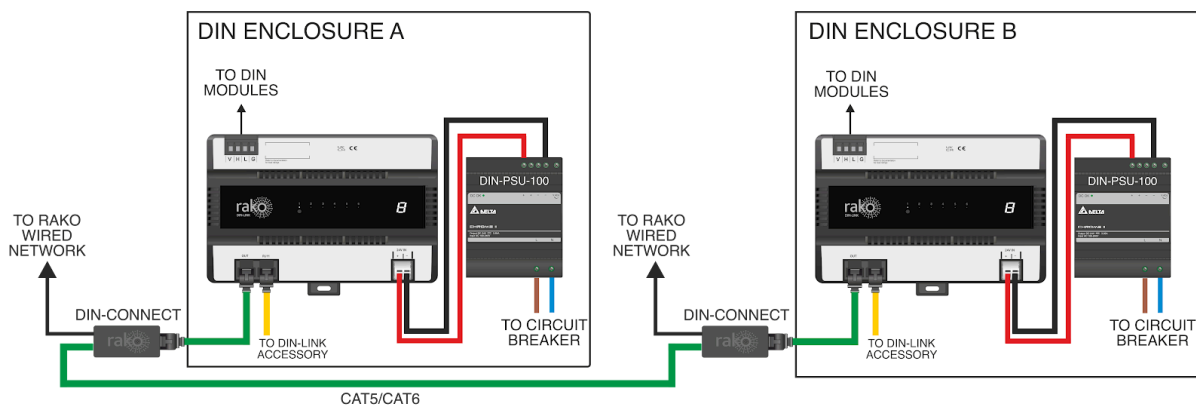

## 8.0 System Configuration & Programming

### 8.1 Rasoft Pro

The Rako DIN system and RWN devices are configured and programmed using Rasoft Pro. Programming involves mapping the DIN modules by assigning outputs to Rooms and Channels. Once this setup is complete, scenes can be created to deliver customised lighting configurations for specific occasions.

RWN devices are then programmed to control the DIN modules according to the intended use case. Instructions for this can be found in the [Wired System Setup Guide](#).

### 8.2 WK-HUB Network Interface

The WK-HUB is essential for programming the RWN and DIN system as it interfaces between Rasoft Pro and the RWN.

Once configured, the WK-HUB enables:

- Control via the Rako App (iOS and Android).
- Integration with third-party control systems and voice assistants (e.g., Amazon Alexa, Google Home, Apple HomeKit).
- Advanced system features such as timed events (including astronomical clock functions for dawn/dusk), holiday mode simulation, macros, and bridging to Rako wireless modules for hybrid system installations.