



Instruction Manual

DIN-CONNECT

DIN-LINK to Rako Wired Network Connector



2026
Version 1.0.1



Contents

1 What is the DIN-CONNECT?.....	3
1.1 Product Image.....	3
1.2 Features of the DIN-CONNECT.....	3
1.3 Example DIN Layout with the DIN-CONNECT.....	3
2 Installation.....	4
3 Terminating the DIN-CONNECT.....	5
4 Troubleshooting the Rako Wired Network.....	5
5 Wiring Examples.....	6
5.1 Radial Wired System.....	6
5.2 STAR Wired System.....	7
5.3 Systems with Multiple DIN-LINKs.....	8

1 What is the DIN-CONNECT?

1.1 Product Image





1.2 Features of the DIN-CONNECT

- Joins the DIN-LINK to the Rako Wired Network
- RJ45 port for DIN-LINK connection
- Krone connector supporting up to two CAT5 connections or two CAT6 connections to the Rako Wired Network
- Work in both Radial and Star wiring arrangements on the Rako Wired Network
- Detailed wiring examples are available in [5.0 Wiring Examples](#).

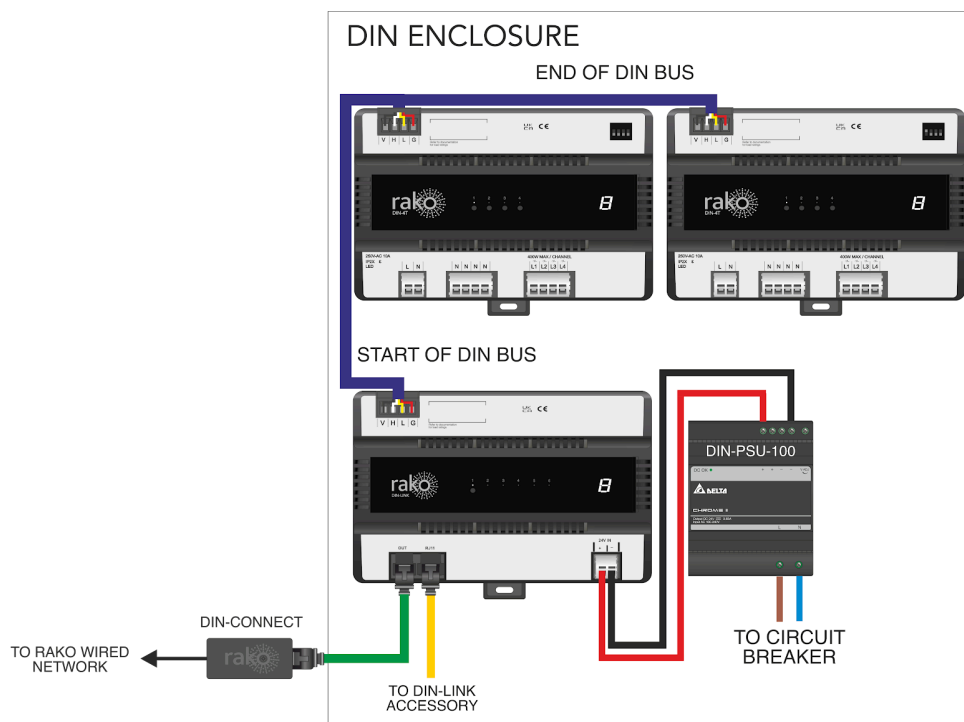
1.3 Example DIN Layout with the DIN-CONNECT

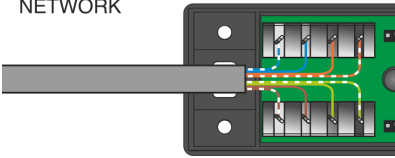
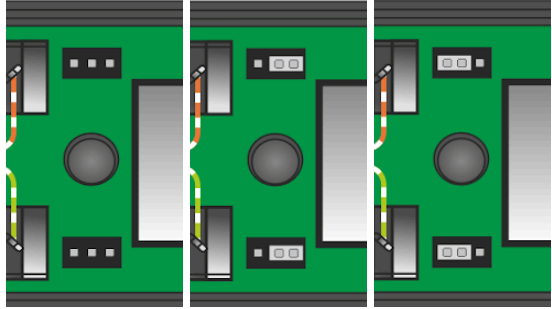
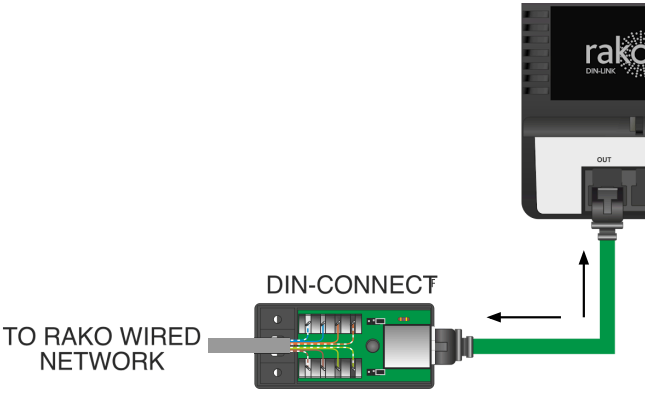

2 Installation

<p>1</p>		<p>Prepare the DIN-CONNECT for connection by unscrewing and removing the cover from the base.</p>
<p>2</p>	<p>CAT5/CAT6 TO RAKO WIRED NETWORK</p> 	<p>Punch down up to two CAT cables into the Krone connector.</p> <p>Ensure that the colours on the cables match the print on the circuit board.</p>
<p>3</p>	 <p>UNTERM STAR TERM</p>	<p>Terminate the DIN-CONNECT as required.</p> <p>For information on setting the termination, see 3.0 Terminating the DIN-CONNECT.</p>
<p>4</p>	 <p>TO RAKO WIRED NETWORK</p> <p>DIN-CONNECT</p> <p>OUT</p>	<p>Connect the RJ45 cable between the DIN-CONNECT and the DIN-LINK.</p>
<p>5</p>		<p>Once all cables are fitted, use the cable ties provided to secure them to the base via the cable restraining points.</p> <p>Replace the cover of the DIN-CONNECT and screw on the lid.</p>

3 Terminating the DIN-CONNECT

The DIN-CONNECT must be terminated correctly, otherwise the wired system will not function. The termination requirements depend on the nature of the installation and the position of the DIN-CONNECT within the system.

No TERM - Both Jumpers removed

When the DIN-CONNECT is not at the end of line. This is usually identifiable by two cables being punched down to the DIN-CONNECT.

TERM - Jumper fitted across 1+2 & 4+5

When the DIN-CONNECT is the end of line in a radial configuration.

STAR TERM - Jumper fitted across 2+3 & 5+6

When the DIN-CONNECT is end of line in a STAR wire configuration.

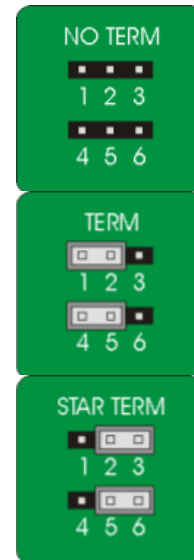

4 Troubleshooting the Rako Wired Network

If any issues are detected on the connected devices on power up, the onboard LEDs provide fault codes. For more information and further diagnostic information, refer to [Wired System Diagnostics](#).

5 Wiring Examples

5.1 Radial Wired System

Connection & Termination Rules:

- End-of-Line Termination: The final device on each end of the radial must be set to the TERM position.
- Intermediate Devices: All other devices on the radial must be set to UN TERM.

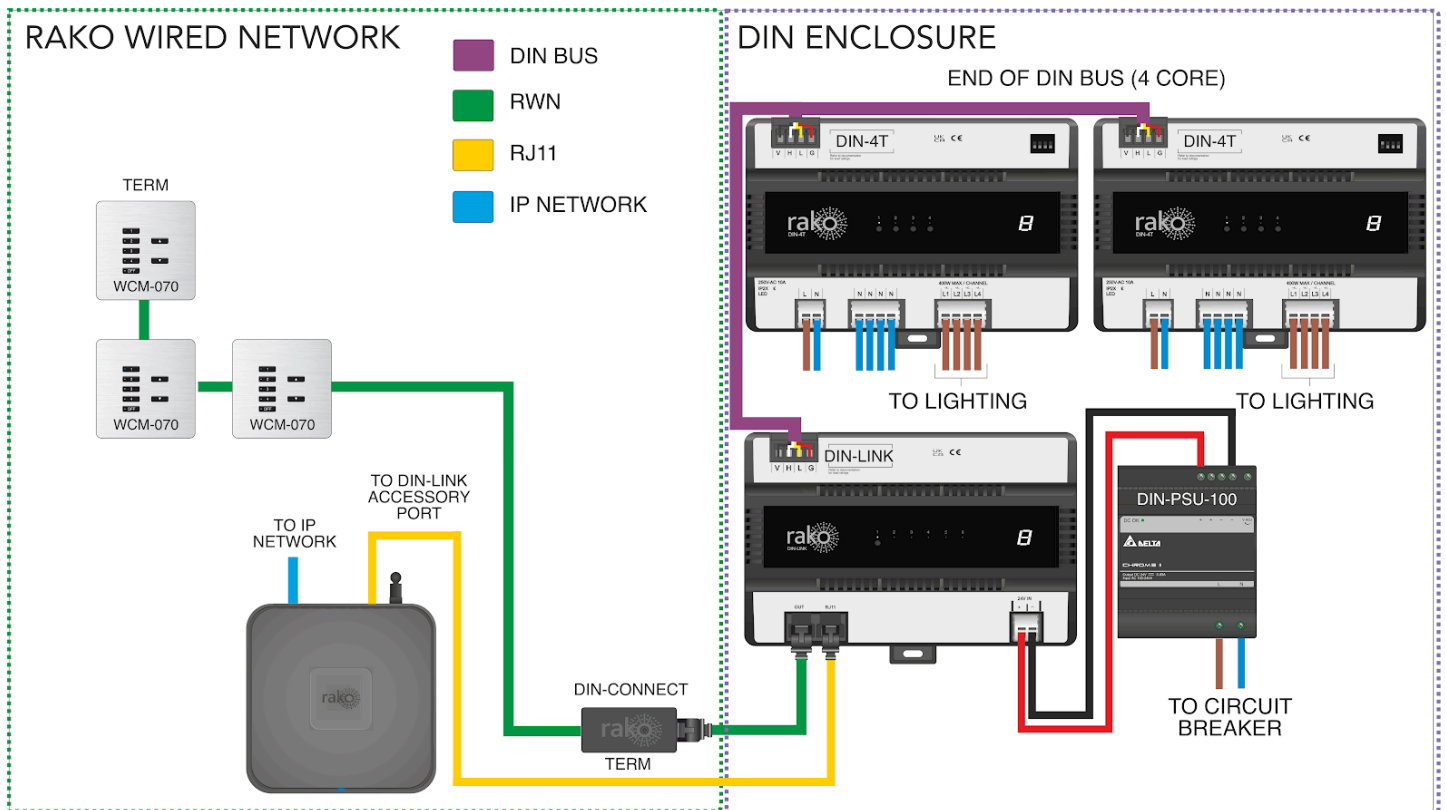

5.2 STAR Wired System

Connection & Termination Rules:

- One CAT Cable Per RAK-STAR Punchdown : Each RAK-STAR punchdown connector must have only one cable. Doubling up cables will lead to system malfunctions.
- End-of-Line Termination: The final device on each leg of the RAK-STAR must be set to the STAR termination position.
- Intermediate Devices: All other devices on a leg (between the RAK-STAR and the end-of-line device) must be set to UN TERM.

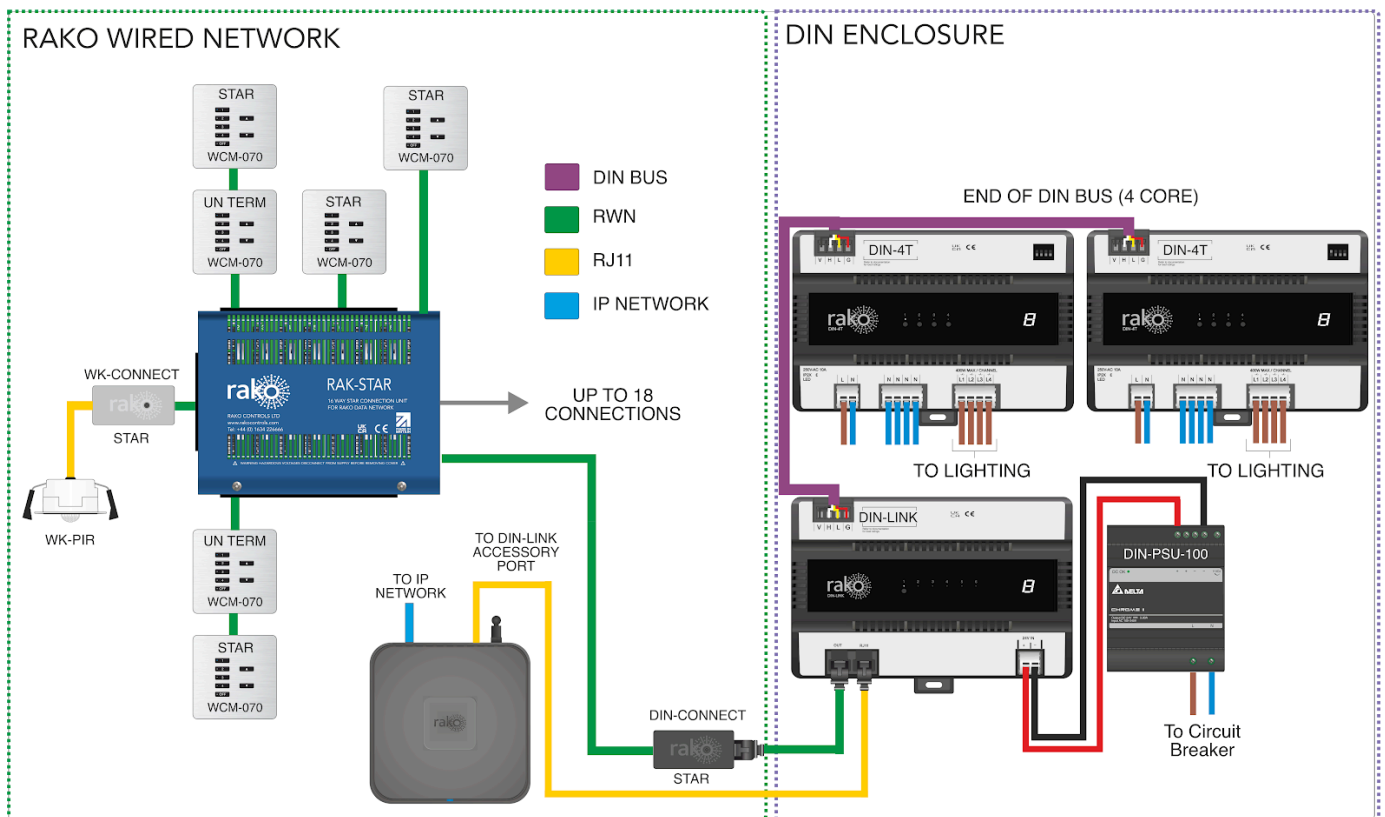

5.3 Systems with Multiple DIN-LINKs

If the DIN system requires more than one DIN-LINK, they must be connected via the Rako Wired Network.

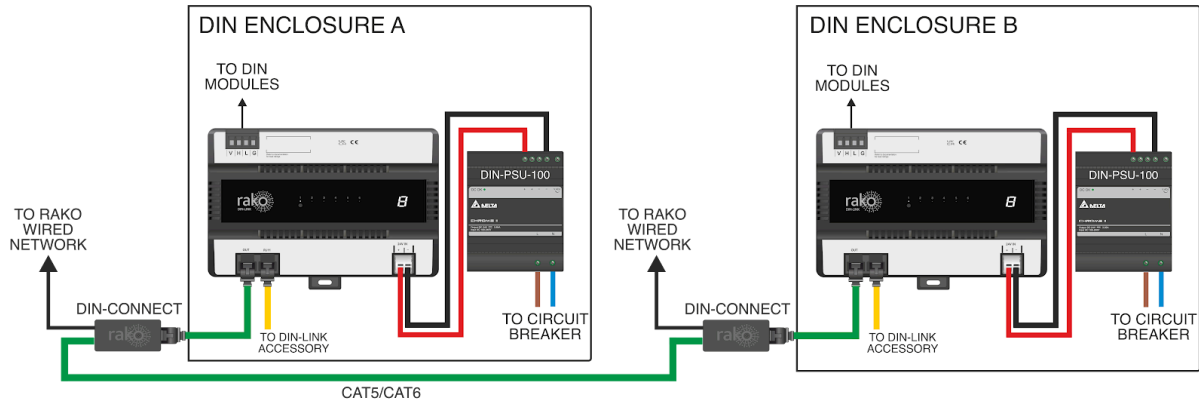

Thank you for choosing Rako Controls; we hope that you are pleased with your system. Should you require further assistance, please contact us via our website, www.rakocontrols.com call our customer support helpline on 01634 226666. The office address is Rako Controls Ltd, Knight Road Rochester, ME2 2AH.



Rako® and the Rako logo are registered trademarks of Rako Controls Ltd. Unauthorised use of these trademarks is prohibited. All other product names, company names, and logos mentioned herein may be trademarks of their respective owners.