

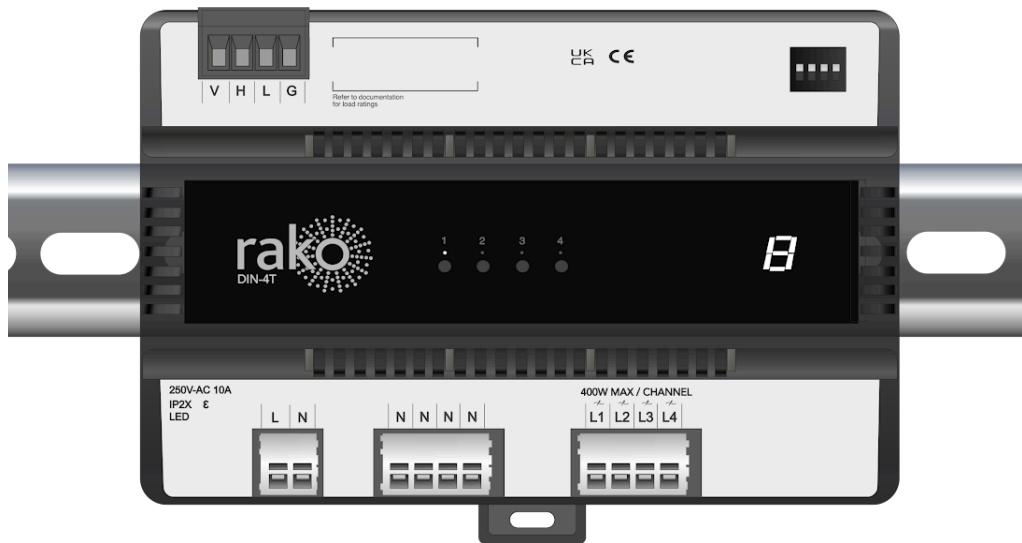

Instruction Manual

DIN-4T

4-Way Trailing Edge Dimmer



2026

Version 1.0.2



Contents

1	What is the DIN-4T?	3
1.1	Product image	3
1.2	Features of the DIN-4T	3
1.3	Load Types	3
1.4	Example DIN layout	4
2	Panel Overview	4
3	DIN-LINK Modules	5
4	Installation Instructions	6
5	Servicing the DIN-4T	8
6	Programming the DIN-4T	9
7	LED Diagnostics	9
7.1	Display	9
7.2	Output LEDs	10
8	Installation Guidelines	11
8.1	Electrical Isolation	11
8.2	Mounting	11
8.3	Enclosure and Environmental Protection	11
8.4	Maximum and Minimum Loadings	11
8.5	Overcurrent Protection	11
8.6	Wiring	11
8.7	Ventilation and Cooling	11
8.8	Compatibility	12
8.9	Third-Party Accessories and Equipment	12

1 What is the DIN-4T?



1.1 Product image



1.2 Features of the DIN-4T

- Four-channel trailing-edge dimmer designed for DIN rail-mounted enclosures.
- WK-HUB is required for configuration using Rako Software
- Controlled via the Rako Wired Network using keypads such as the WK-MOD or WCM.
- Controlled by Rako Wireless Keypads, such as the RK-MOD and RNC, when used in conjunction with a WK-HUB or WRB100.

1.3 Load Types

Load Type	Examples	Maximum Load
LED	Trailing Edge LED fittings*: GU10, integrated, LED tape, driver etc	200W/Channel
 Incandescent	Mains halogens, tungsten fittings, etc	400W/Channel
 Low Voltage Transformer	Electronic transformer, 12V MR16 Gu5.3 Halogen etc	300W ($\cos \phi \Rightarrow 0.6$)

Defined by IEC/EN 60669-2-5

1.4 Example DIN layout

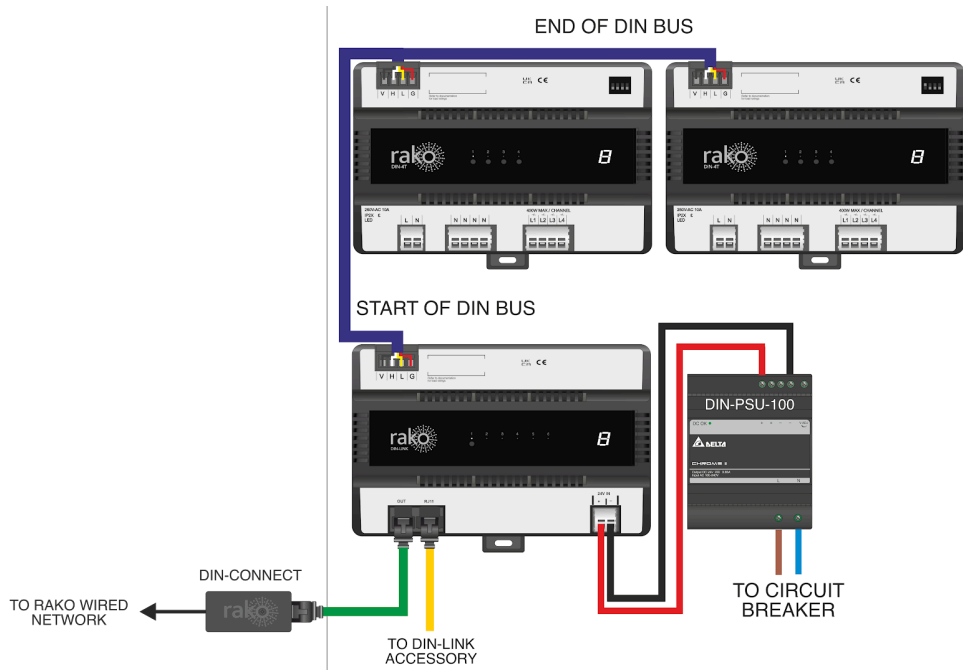

2 Panel Overview

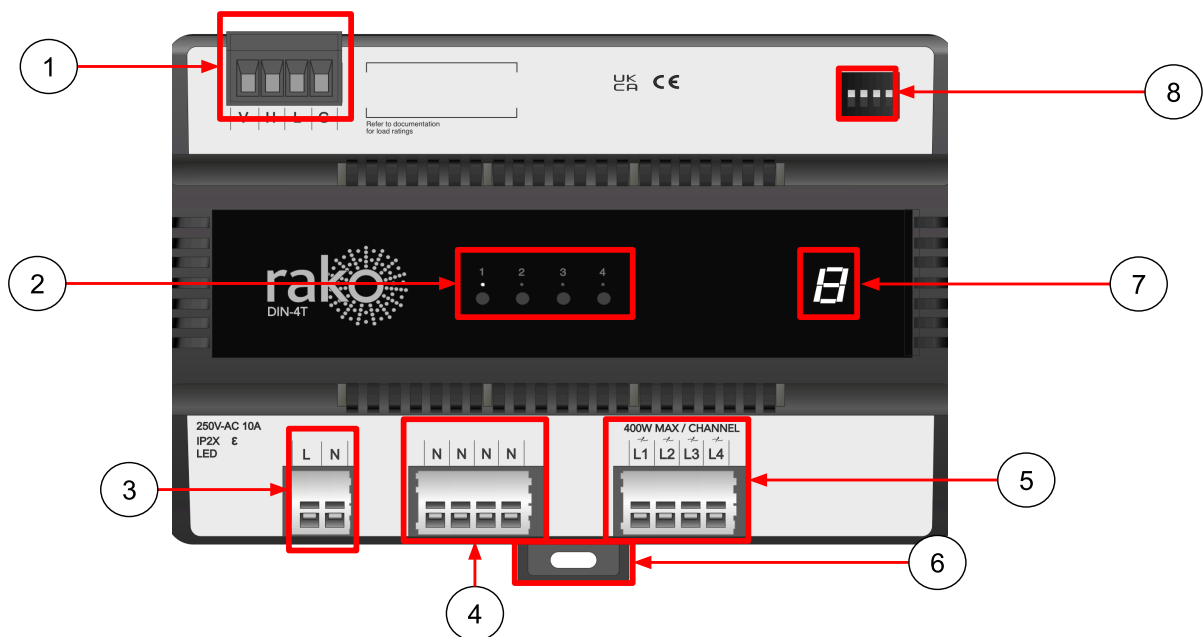





No.	Description
1	The input terminals for the DIN bus.
2	LED indicators and manual test buttons.
3	Supply IN.
4	Load neutral connections.
5	Dimmed load outputs.
6	Locks the DIN-4T to the DIN rail when the clip is pushed up.
7	Seven-segment display for diagnostic feedback.
8	The DIN-4T is identified by its box number set during the programming.

3 DIN-LINK Modules

The DIN-LINK is used to communicate with four types of modules: DIN-4T, DIN-8S, DIN-4C and DIN-DLI.

Each DIN-LINK module is connected via the DIN bus. The DIN-LINK has a maximum capacity calculated in DIN Power Units (DPU). The maximum DPU per DIN-LINK is 64.

Device	Description	Diagram	DPU
DIN-4T	Four-channel trailing edge dimmer module. It is suitable for controlling mains dimmable loads.		8
DIN-8S	Eight-channel relay module for on/off switching.		8
DIN-4C	A four-channel curtain and blind controller module.		8

DIN-DLI	Multi Room DALI Controller		16
---------	----------------------------	--	----

4 Installation Instructions

⚠WARNING

- The overall safety of any system incorporating this equipment is the responsibility of the assembler of the end system.
- A qualified electrician must install the DIN module. Ensure all wiring follows local electrical standards. Use only appropriately rated cables, and secure all connections before powering on.
- The DIN module must be connected to a mains supply that includes appropriate protective devices. Failure to comply with these requirements may result in damage to the equipment, risk of fire, or electrical hazards.

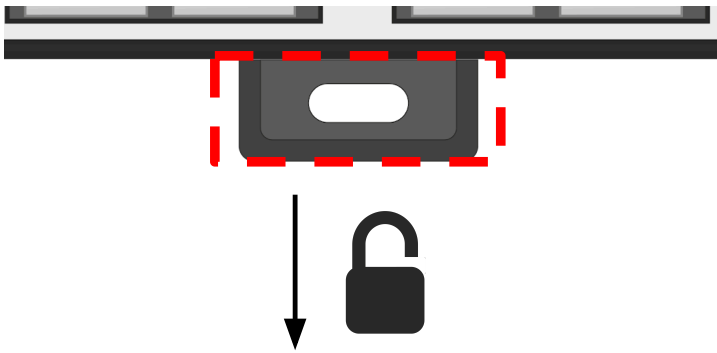
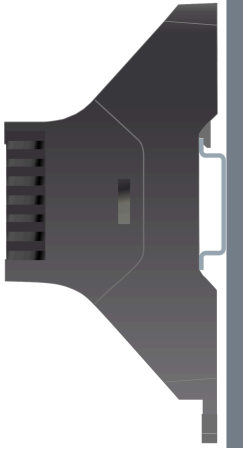
1		Pull down the DIN clamp at the bottom of the unit to unlock it.
2		Once unlocked, place the DIN-4T over the DIN rail.

3

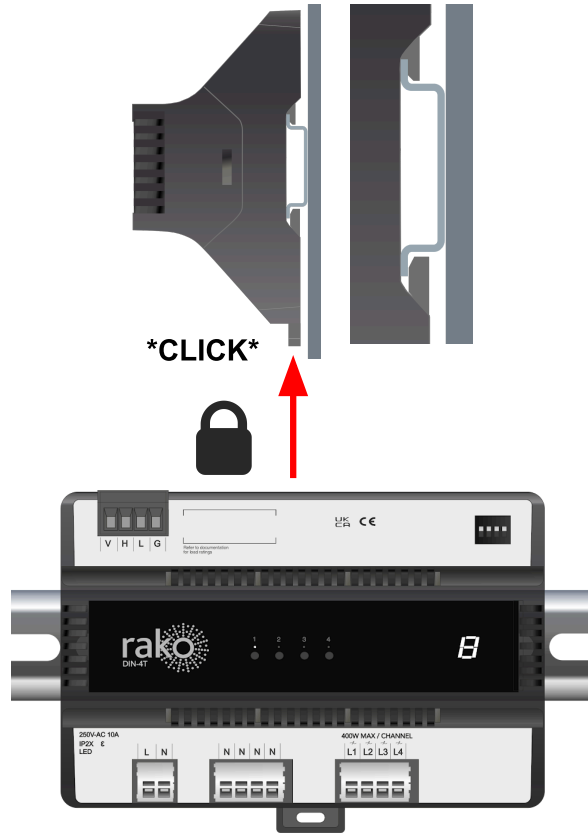

Push the clamp tab up to lock the DIN-4T to the DIN rail.

5

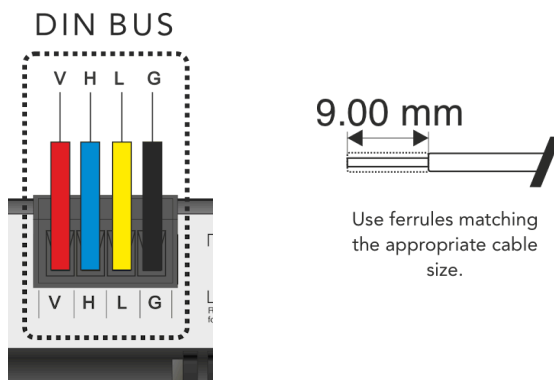

Connect the DIN bus to the top left terminals.

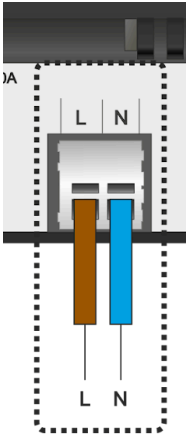
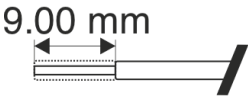
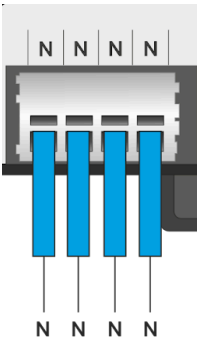
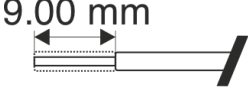
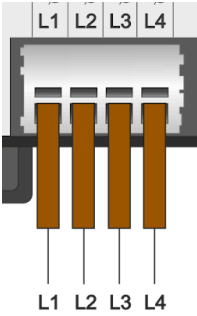
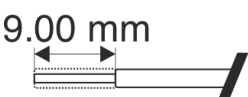
6	 <p style="text-align: center;">MAINS IN</p>  <p style="text-align: center;">9.00 mm</p> <p style="text-align: center;">Use ferrules matching the appropriate cable size.</p>	Connect the input conductors
7	  <p style="text-align: center;">9.00 mm</p> <p style="text-align: center;">Use ferrules matching the appropriate cable size.</p>	Connect the neutral conductors for the output loads.
8	  <p style="text-align: center;">9.00 mm</p> <p style="text-align: center;">Use ferrules matching the appropriate cable size.</p>	Connect the live conductors for the output loads.

5 Servicing the DIN-4T

The DIN-4T contains no user-serviceable parts; should the unit require a repair, it must be returned via the online form at <https://returns.rakocontrols.com/contact/service-returns/>.

6 Programming the DIN-4T



The DIN-4T is programmed using the Rasoft Pro programming software. A WK-HUB is required for any programming of a Rako Wired DIN system. Instructions for this can be found in the [Wired System Setup Guide](#).

7 LED Diagnostics

7.1 Display

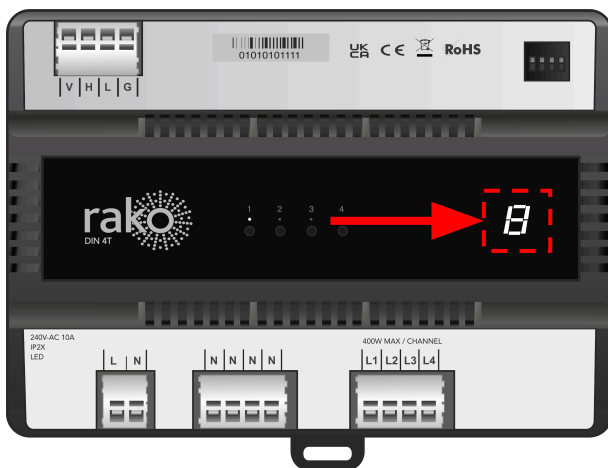
DIN modules use a seven-segment display for diagnostic information.



<p style="text-align: center;">Bootloader</p> <hr/> <p>When the DIN module is updating firmware, the device will be put into bootloader.</p>	
<p style="text-align: center;">Bootloader Sleep</p> <hr/> <p>Once a firmware update has commenced, the bootloader will enter Bootloader Sleep and wait for the upgrade to complete.</p>	
<p style="text-align: center;">Local Channel</p> <hr/> <p>When receiving data from the DIN-LINK, the DIN module will flash 'L.' when receiving a command.</p>	

Error	
When the test button is pressed, and there is an error communicating with the DIN module, 'E' will appear on the display.	

7.2 Output LEDs

LED	Description	Pattern	Possible Cause
1 to 4 (Channel Specific)	Bootloader	Slow Flash ~1 seconds	The channel is in bootloader; this occurs during the firmware upgrade process.
1 to 4 (Channel Specific)	Over Temperature	Fast Flash ~0.25 seconds	The DIN module's temperature is monitored; if the temperature is too high, the load will switch off to prevent damage.
1 to 4 (Channel Specific)	Zero-Cross Fault	Double Flash ~0.5 seconds every 2 pulses	Bypass the load on a permanent supply and check that the load is switching.
1 to 4 (Channel Specific)	Overload Protection	Intermittent Flash	If the current on the output is too high for too long, check the total load on the output and reduce it

8 Installation Guidelines

⚠ WARNING

If the equipment is used in a manner not specified by the manufacturer, the protection provided by the equipment may be impaired.

8.1 Electrical Isolation

A disconnect device must be provided in the installation and must be all-pole. It must be clearly labelled and positioned so that it is not obstructed by enclosures, wiring, or heavy equipment, ensuring ease of access for maintenance and emergency disconnection.

Ensure the power supply is isolated before starting any installation or maintenance; failure to do so may result in electrical shock or injury.

8.2 Mounting

The DIN-4T module is designed for mounting on a DIN rail. Ensure the module is securely mounted within a compliant DIN enclosure.

8.3 Enclosure and Environmental Protection

Install the DIN-4T module in a suitably rated enclosure that protects against dust, moisture, and other contaminants according to its environment; failure to do so may lead to damage or malfunction.

8.4 Maximum and Minimum Loadings

The load capacity of the DIN-4T module is load-type dependent; refer to the 'Specification' section of the instruction manual to ensure the load is within the specified limits. Exceeding these limits may cause output failure.

8.5 Overcurrent Protection

Install appropriate overcurrent protection in line with the module, based on the electrical load and supply, to protect the module from potential short circuits or overloads.

8.6 Wiring

All wiring should comply with the current local wiring regulations. This includes selecting the correct cable size, using appropriate termination methods, and ensuring mechanical protection for the wiring.

8.7 Ventilation and Cooling

Ensure sufficient ventilation within the DIN enclosure to prevent overheating. Poor ventilation can lead to overheating and module failure.

8.8 Compatibility

Verify that the DIN-4T module is compatible with other electrical components in the system. Incompatibility may result in malfunction, reduced performance, or damage to the module.

Do not connect third-party devices to the Rako DIN bus.

8.9 Third-Party Accessories and Equipment

The installer is responsible for providing the necessary cables, isolators, electrical loads, and ferrules compatible with the terminals on the DIN-4T unit.

Refer to the manufacturer's instructions for all third-party devices.

All cables must be appropriately rated for the intended load and comply with the relevant electrical standards.

Thank you for choosing Rako Controls; we hope that you are pleased with your system. Should you require further assistance, please contact us via our website, www.rakocontrols.com call our customer support helpline on 01634 226666. The office address is Rako Controls Ltd, Knight Road Rochester, ME2 2AH.



Rako® and the Rako logo are registered trademarks of Rako Controls Ltd. Unauthorised use of these trademarks is prohibited. All other product names, company names, and logos mentioned herein may be trademarks of their respective owners.