

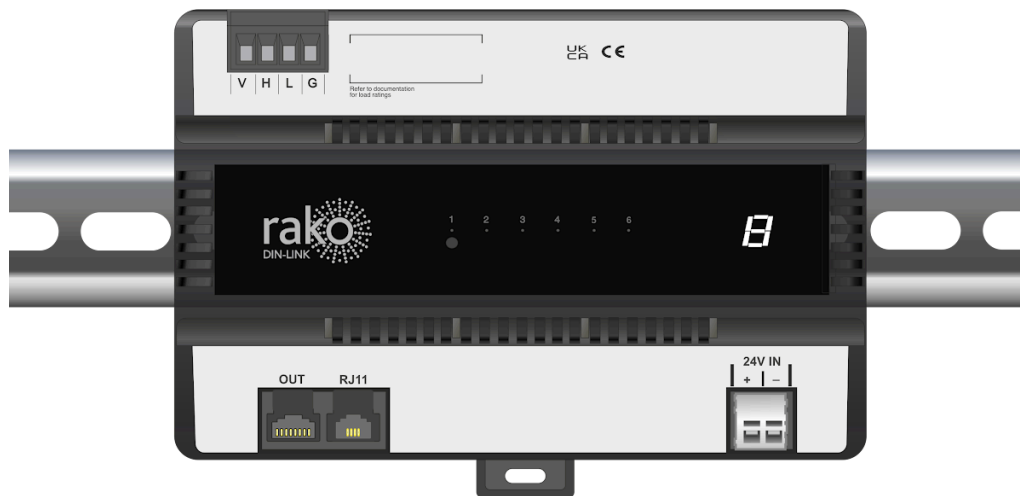

Instruction Manual

DIN-LINK

Rako Wired Network DIN Bus Connection Unit



2026

Version 1.0.3



Contents

1 What is the DIN-LINK?.....	3
1.1 Product Image.....	3
1.2 Features of the DIN-LINK.....	3
1.3 Example DIN Layout.....	3
2 Panel Overview.....	4
3 DIN-LINK Modules.....	5
4 Installation Instructions.....	6
5 Programming the DIN-LINK.....	8
6 LED Diagnostics.....	8
6.1 Display.....	8
6.2 Output LEDs.....	9
7 Troubleshooting the Rako Wired Network.....	9
8 Servicing the DIN-LINK.....	10
9 System Examples.....	10
9.1 Radial Wired System.....	10
9.2 STAR Wired System.....	11
9.3 Systems with Multiple DIN-LINKs.....	11

1 What is the DIN-LINK?

1.1 Product Image



1.2 Features of the DIN-LINK

- Communicator and power source for the Rako Wired Network and DIN bus
- DIN bus port for connecting to DIN modules
- RJ45 port for connecting to the DIN-CONNECT for the Rako Wired Network
- Programmed using Rasoft Pro to map DIN module outputs into Rooms and Channels
- RJ11 port for connection to a HUB or a Rako Wired Network Accessory
- Requires a DIN-CONNECT and a DIN-PSU-100 to operate

1.3 Example DIN Layout

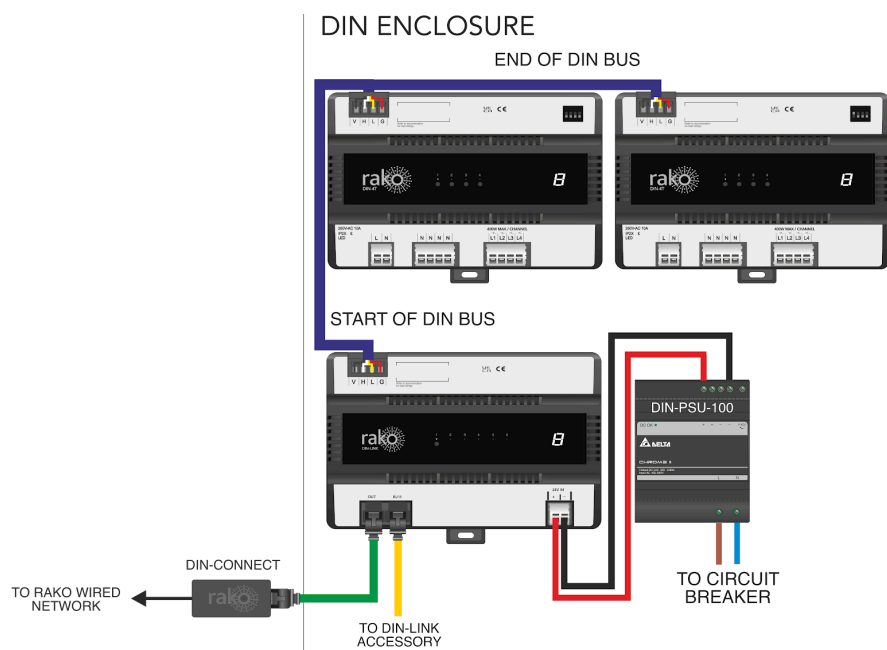

2 Panel Overview

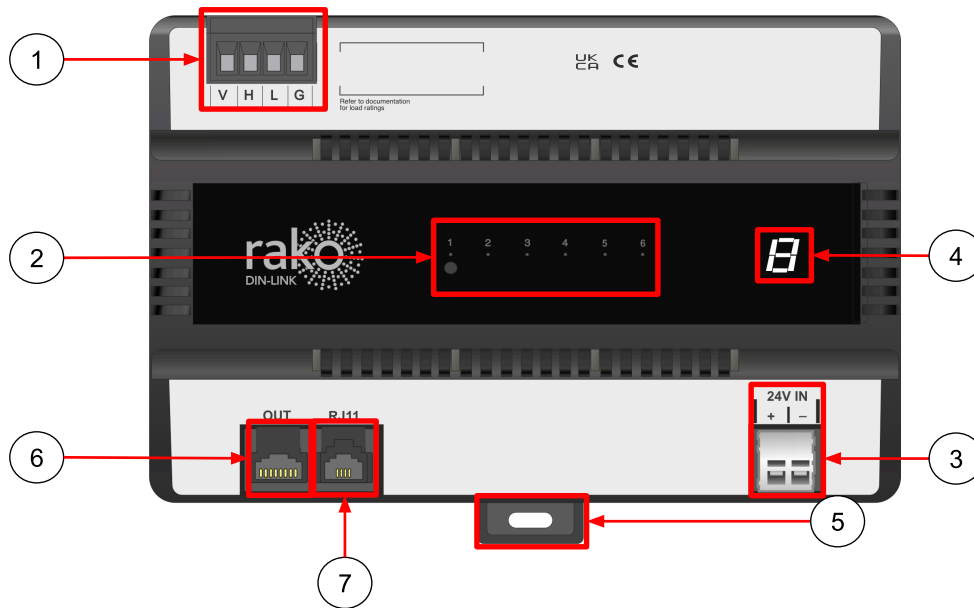





No.	Description
1	The input terminals for the DIN bus.
2	LEDs 1-6 are used for diagnostic feedback, the setup button is used for setup mode and device polling.
3	Input terminal from the 24V DC power supply via the DIN-PSU-100.
4	Seven-segment display for diagnostic feedback.
5	Lock for the DIN-LINK to the DIN rail.
6	RJ45 port for the connection to the Rako Wired Network (Maximum of 30 Devices Per DIN-LINK)
7	RJ11 port for connection to a HUB or Rako Wired Network Accessory (Maximum of 1)

3 DIN-LINK Modules

The DIN-LINK is used to communicate with four types of modules: DIN-4T, DIN-8S, DIN-4C and DIN-DLI.

Each DIN-LINK module is connected via the DIN bus. The DIN-LINK has a maximum capacity calculated in DIN Power Units (DPU). The maximum DPU per DIN-LINK is 64.

Device	Description	Diagram	DPU
DIN-4T	Four-channel trailing-edge dimmer module. It is suitable for controlling mains dimmable loads.		8
DIN-8S	Eight-channel relay module for on/off switching.		8
DIN-4C	A four-channel curtain and blind controller module.		8
DIN-DLI	Multi-room DALI Controller		16

4 Installation Instructions

⚠ WARNING

- The overall safety of any system incorporating this equipment is the responsibility of the assembler of the end system.
- A qualified electrician must install the DIN module. Ensure all wiring follows local electrical standards. Use only appropriately rated cables, and secure all connections before powering on.
- The DIN module must be connected to a mains supply that includes appropriate protective devices. Failure to comply with these requirements may result in damage to the equipment, risk of fire, or electrical hazards.

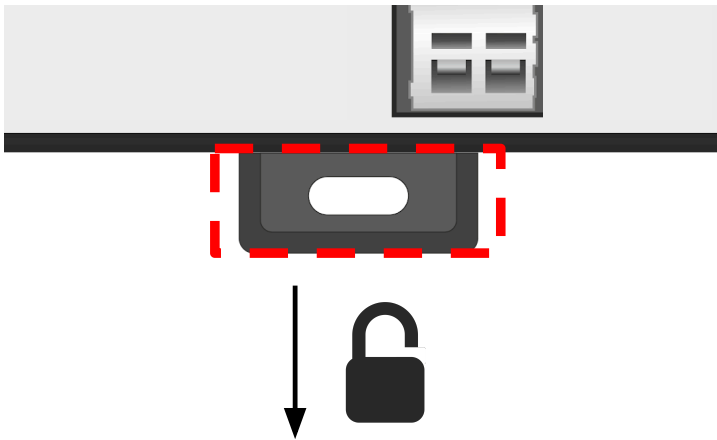
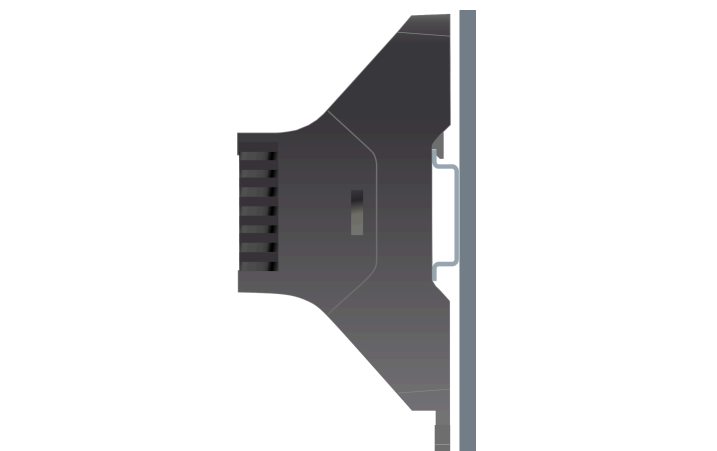
1	 <p>The diagram shows a top-down view of a grey rectangular unit with a square window on the right side. Below the unit, a black DIN clamp is shown with a red dashed outline. A black arrow points downwards from the clamp, and a black padlock icon is positioned to the right of the arrow, indicating the locking mechanism.</p>	Pull down the DIN clamp at the bottom of the unit to unlock it.
2	 <p>The diagram shows a side view of a black DIN-LINK component being inserted onto a vertical grey DIN rail. The DIN-LINK has a series of pins on its left side and a hook-like structure on its right side that fits over the rail.</p>	Once unlocked, place the DIN-LINK over the DIN rail.

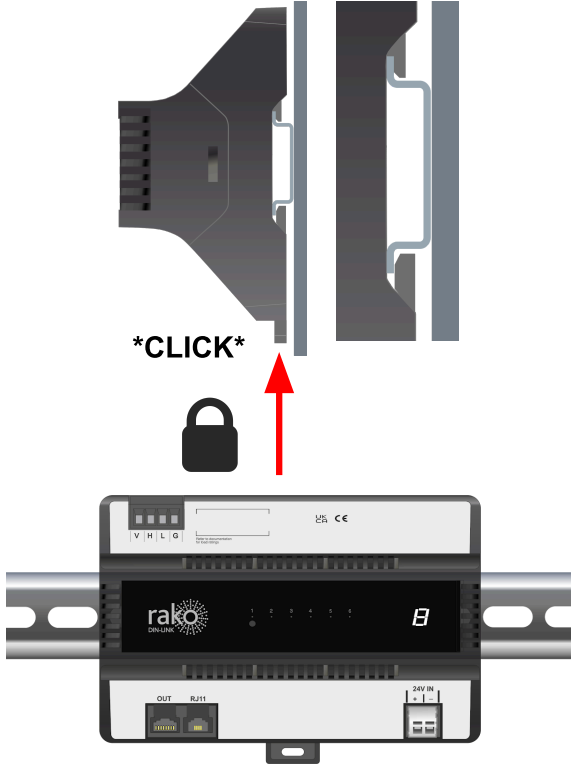
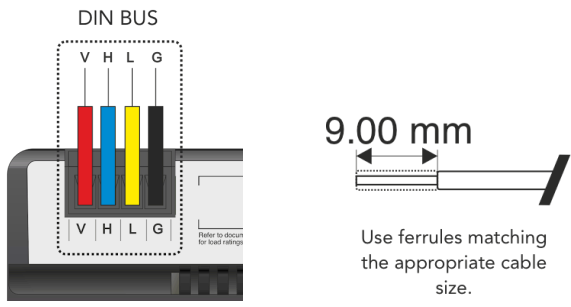
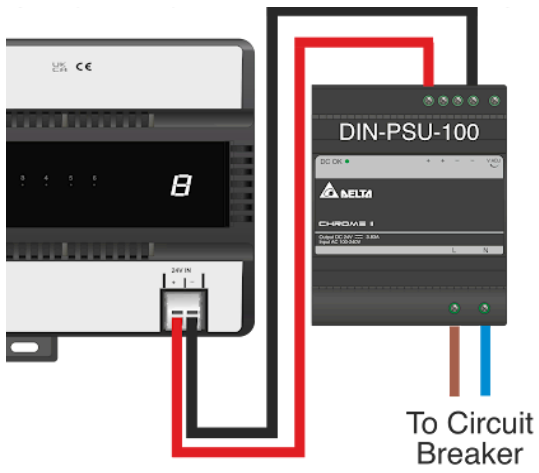
<p>3</p>		<p>Push the clamp tab up to lock the DIN-LINK to the DIN rail.</p>
<p>4</p>		<p>Connect the DIN bus to the top left terminals.</p> <p>When connecting multiple DIN modules via a single DIN bus, use a loop-in/loop-out wiring arrangement.</p>
<p>5</p>		<p>Connect the 24V DC input from the DIN-PSU-100</p>

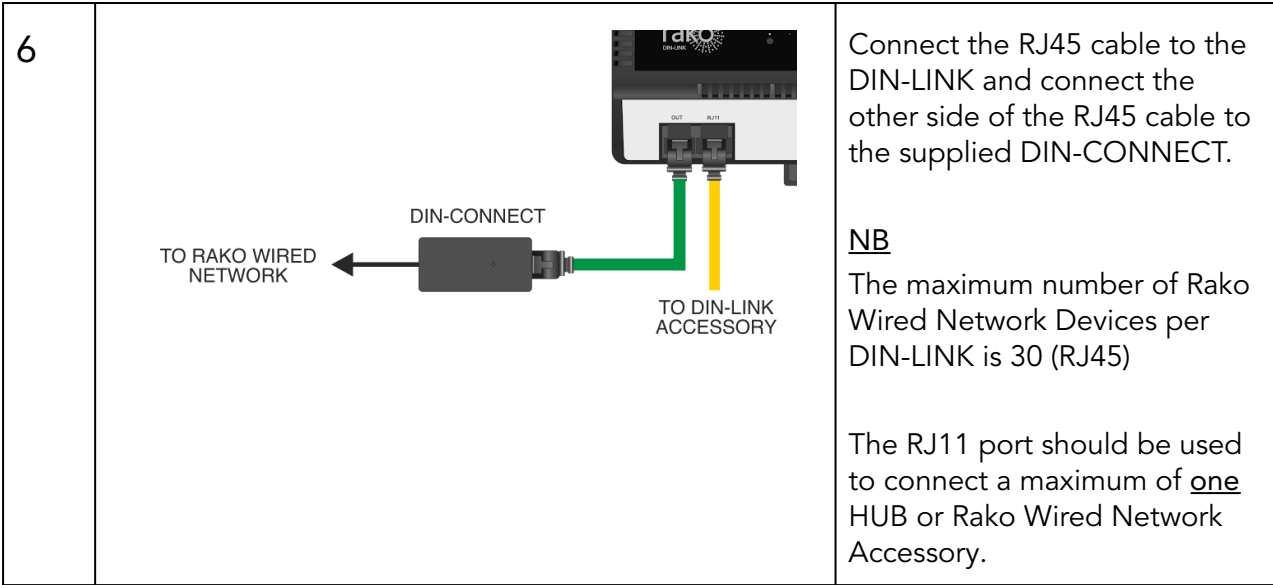

5 Programming the DIN-LINK



The DIN-LINK is programmed using the Rasoft Pro programming software. A WK-HUB is required for any programming of a Rako Wired DIN system. Instructions for this can be found in the [Wired System Setup Guide](#).

6 LED Diagnostics

6.1 Display

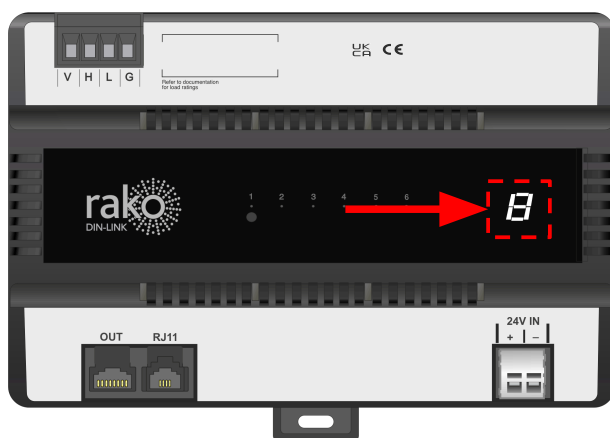
The DIN-LINK has a seven-segment display for diagnostic information.



<p>Bootloader</p> <hr/> <p>When the DIN module is updating firmware, the device will be put into bootloader.</p>	
<p>Bootloader Sleep</p> <hr/> <p>Once a firmware update has commenced, the bootloader will enter Bootloader Sleep and wait for the upgrade to complete.</p>	

6.2 Output LEDs

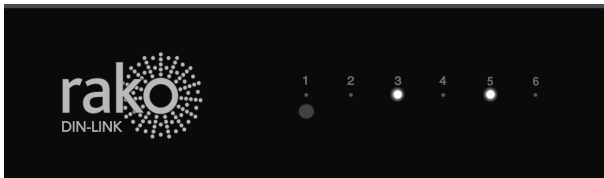

LEDs 3 and 5 on the DIN-LINK should always be illuminated under normal operating conditions.

LED	Description	LED Pattern	Cause
1	Device Activity	Solid	Button Held
1	Device Activity	Slow Flash ~1 second	Setup Mode
2	Activity	Rapid Intermittent Flashing	Data
3	RWN Power	Solid	Normal Operation
4	RWN Fault	Slow Flash ~1 seconds	Fault on the RWN
5	DIN Bus Power	Solid	Normal Operation
6	DIN Bus Fault	Flashing ~1 second	DIN Bus Fault

7 Troubleshooting the Rako Wired Network

If any issues are detected on the connected devices on power up, the onboard LEDs provide fault codes. For more information and further diagnostic information, refer to [Wired System Diagnostics](#).

8 Servicing the DIN-LINK

The DIN-LINK contains no user-serviceable parts; should the unit require a repair, it must be returned via the online form at <https://returns.rakocontrols.com/contact/service-returns/>.

If the DIN-LINK has been returned from a repair, ensure it is operating correctly in the system by testing the following:

- Check that the input voltage matches the required specifications (see datasheet) to ensure proper operation of the unit.
- Verify the communication by testing the DIN-LINK with either a Keypad or Rasoft Pro software with the connected DIN modules.

9 System Examples

9.1 Radial Wired System

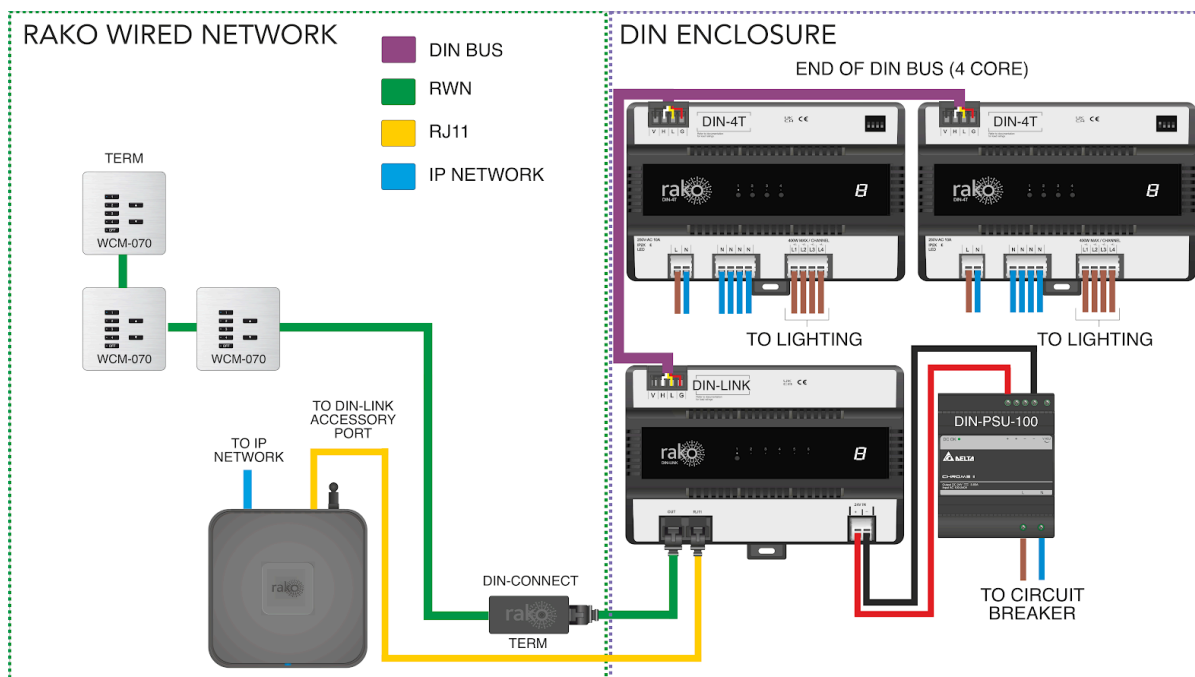

9.2 STAR Wired System

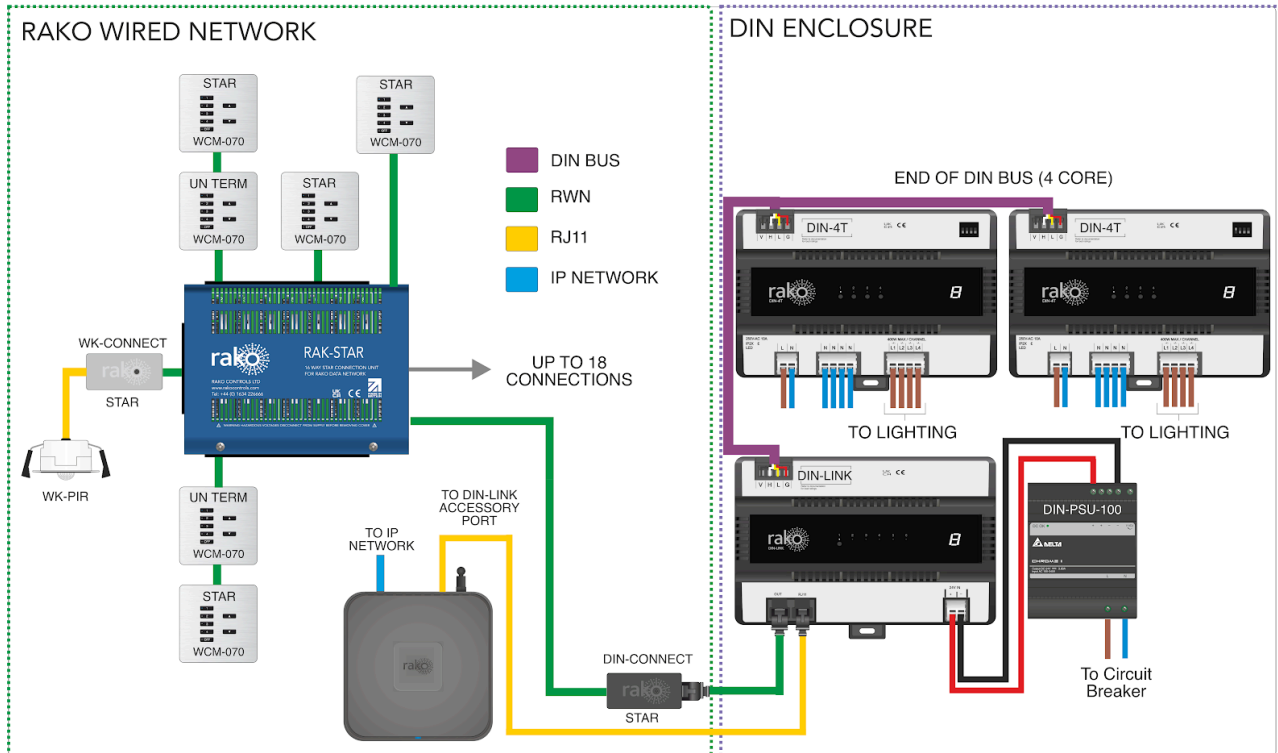

9.3 Systems with Multiple DIN-LINKs

If the DIN system requires more than one DIN-LINK, they must be connected via the Rako Wired Network.

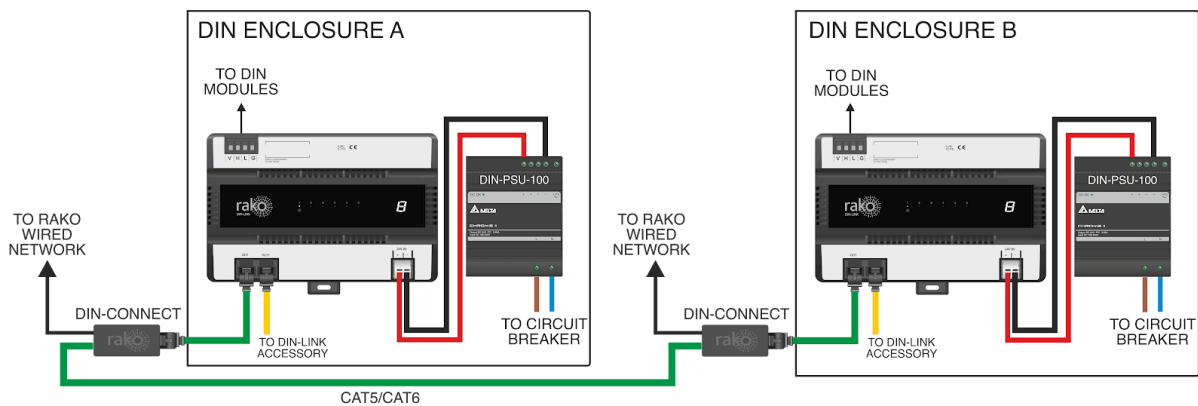

Thank you for choosing Rako Controls; we hope that you are pleased with your system. Should you require further assistance, please contact us via our website, www.rakocontrols.com call our customer support helpline on 01634 226666. The office address is Rako Controls Ltd, Knight Road Rochester, ME2 2AH.

